

## 150V N-Channel Enhancement Mode MOSFET

### Description

The PECN1510D6 uses trench MOSFET technology that is uniquely optimized to provide the most efficient high frequency switching performance. Conduction and switching losses are minimized due to an extremely low combination of  $R_{DS(ON)}$  and  $C_{rss}$ .

### General Features

- ◆  $V_{DS} = 150V$   $I_D = 10A$   
 $R_{DS(ON)}(Typ.) = 240m\Omega$  @  $V_{GS} = 10V$   
 $R_{DS(ON)}(Typ.) = 255m\Omega$  @  $V_{GS} = 4.5V$
- ◆ Lead free product is acquired
- ◆ Surface mount package

### Application

- ◆ High Frequency Point-of-Load Synchronous Buck Converter for MB/NB/UMPC/VGA
- ◆ Networking DC-DC Power System
- ◆ Load switch

### Package

- ◆ PDFN5\*6-8L-A

*100% UIS TESTED!*

*100%  $\Delta V_{ds}$  TESTED!*

### Schematic diagram

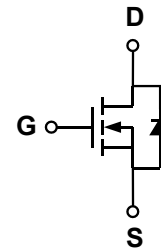

### Marking and pin assignment

PDFN5\*6-8L-A

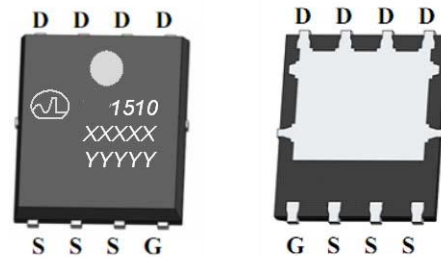

Top View

Bottom View

XXXX—Date Code

YYYY—Quality Code

### Ordering Information

Part Number	Storage Temperature	Package	Devices Per Reel
PECN1510D 6-G	-55°C to +150°C	PDFN5*6-8L-A	4000

### Absolute Maximum Ratings (TA=25°C unless otherwise noted)

parameter	symbol	limit	unit	
Drain-source voltage	$V_{DS}$	150	V	
Gate-source voltage	$V_{GS}$	±20	V	
Continuous Drain Current	$I_D$	TC=25°C	10	A
		TC=100°C	7	
Pulsed Drain Current	$I_{DP}$	12	A	
Avalanche energy( L=0.1mH)	$E_{AS}$	14	mJ	
Maximum power dissipation	$P_D$	TC=25°C	37.5	W
		TC=75°C	15	
Power Dissipation – Derate above 25°C				
Operating junction Temperature range	$T_j$	-55—150	°C	

## Electrical Characteristics (TA=25°C unless otherwise noted)

Parameter	Symbol	Condition	Min	Typ	Max	Unit
<b>Static Characteristics</b>						
Drain-source breakdown voltage	$BV_{DSS}$	$V_{GS}=0V, I_D=250\mu A$	150	-	-	V
BVDSS Temperature Coefficient	$\Delta BV_{DSS}/\Delta T_J$	Reference to 25°C, $I_D=1mA$		33		mV/°C
Zero gate voltage drain current	$I_{DSS}$	$V_{DS}=150V, V_{GS}=0V$	-	-	1	$\mu A$
		$T_J=85^\circ C$	-	-	30	
Gate Leakage Current	$I_{GSS}$	$V_{DS}=0V, V_{GS}=\pm 20V$	-	-	$\pm 100$	nA
Gate threshold voltage	$V_{GS(th)}$	$V_{DS}=V_{GS}, I_D=250\mu A$	1.5	2.2	3.0	V
Drain-source on-state resistance <sup>1</sup>	$R_{DS(ON)}$	$V_{GS}=10V, I_D=10A$	-	240	255	mΩ
		$V_{GS}=4.5V, I_D=8A$		255	270	
On Status Drain Current	$I_{D(ON)}$	$V_{DS}=5V, V_{GS}=4V$	3	-	-	A
<b>Diode Characteristics</b>						
Diode Forward Voltage <sup>1</sup>	$V_{SD}$	$I_{SD}=1A, V_{GS}=0V$	-	0.8	1.1	V
Diode Continuous Forward Current	$I_S$		-	-	3	A
Reverse Recovery Time	$t_{rr}$	$I_F=10A,$	-	30	-	ns
Reverse Recovery Charge	$Q_{rr}$	$dI/dt=100A/us$	-	44	-	nC
<b>Dynamic Characteristics<sup>2</sup></b>						
Gate Resistance	$R_G$	$V_{GS}=0V, V_{DS}=0V, f=1MHz$	-	3.3	-	Ω
Input capacitance	$C_{ISS}$	$V_{GS}=0V, V_{DS}=15V$ $f=1.0MHz$	-	900	-	pF
Output capacitance	$C_{OSS}$		-	99	-	
Reverse transfer capacitance	$C_{RSS}$		-	75	-	
Turn-on delay time	$t_{D(ON)}$	$V_{DD}=75V, I_D=10A,$ $V_{GS}=10V, R_{GEN}=6\Omega$	-	10	-	ns
Turn-on Rise time	$t_r$		-	11	-	
Turn-off delay time	$t_{D(OFF)}$		-	58	-	
Turn-off Fall time	$t_f$		-	22	-	
Total gate charge	$Q_g$	$V_{GS}=4.5V,$ $I_D=10A, V_{DS}=75V$	-	12		nC
Gate-source charge	$Q_{gs}$		-	3.2		
Gate-drain charge	$Q_{gd}$		-	6.4	-	

Note: 1: Pulse test; pulse width  $\leq 300ns$ , duty cycle  $\leq 2\%$ .

2: Guaranteed by design, not subject to production testing.

## Thermal Characteristics

Parameter	Symbol	Typ	Max	Unit
Maximum Junction-to-Ambient <sup>A</sup>	$R_{\theta JA}$	12	20	°C/W
Maximum Junction-to-Ambient <sup>A</sup>		Steady-State	33	
Maximum Junction-to-Lead <sup>B</sup>	$R_{\theta JC}$	2.4	2.9	

A: The value of  $R_{\theta JA}$  is measured with the device mounted on 1in 2 FR-4 board with 2oz. Copper, in a still air environment

with  $T_A=25^{\circ}\text{C}$ . The value in any given application depends on the user's specific board design. The current rating is based on the  $t \leq 10\text{s}$  thermal resistance rating.

B: The  $R_{\theta JA}$  is the sum of the thermal impedance from junction to lead  $R_{\theta JC}$  and lead to ambient.

## Package Information

- PDFN5\*6-8L-A

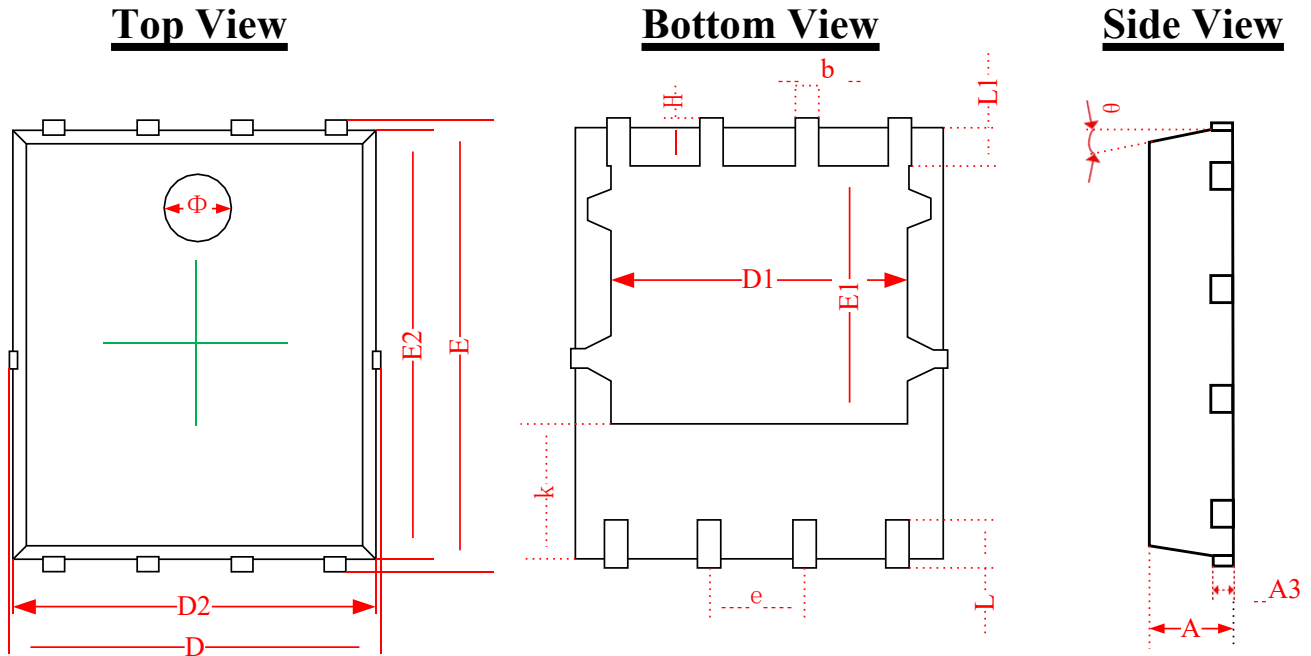

SYMBOLS	DIMENSIONS IN MILLIMETERS			DIMENSIONS IN INCHES		
	MIN	NOM	MAX	MIN	NOM	MAX
A	0.870	0.900	0.930	0.034	0.035	0.036
A3	0.152REF.			0.006REF.		
D	4.944	5.020	5.096	0.195	0.198	0.201
E	5.974	6.050	6.126	0.235	0.238	0.241
D1	3.910	4.010	4.110	0.154	0.158	0.162
E1	3.375	3.475	3.575	0.133	0.137	0.141
D2	4.870	4.900	4.930	0.192	0.193	0.194
E2	5.720	5.750	5.780	0.226	0.227	0.228
k	1.190	1.290	1.390	0.047	0.051	0.055
b	0.350	0.380	0.410	0.014	0.015	0.016
e	1.270TYP.			0.050TYP.		
L	0.559	0.635	0.711	0.022	0.025	0.028
L1	0.424	0.500	0.576	0.017	0.020	0.023
H	0.574	0.650	0.726	0.023	0.026	0.029
θ	10°	11°	12°	10°	11°	12°
Φ	1.150	1.200	1.250	0.045	0.047	0.049