

N-Channel Enhancement Mode MOSFET

Description

The PECN2300MR uses advanced trench technology to provide excellent $R_{DS(ON)}$, low gate charge and high density cell Design for ultra low on-resistance. This device is suitable for use as a load switch or in PWM applications.

General Features

- ◆ $V_{DS} = 20V$, $I_D = 5A$
 $R_{DS(ON)}(Typ.) = 30m\Omega$ @ $V_{GS} = 2.5V$
 $R_{DS(ON)}(Typ.) = 24m\Omega$ @ $V_{GS} = 4.5V$
- ◆ High power and current handling capability
- ◆ Lead free product is acquired
- ◆ Surface mount package

Application

- ◆ PWM applications
- ◆ Load switch

Package

- ◆ SOT-23-3L



Schematic diagram

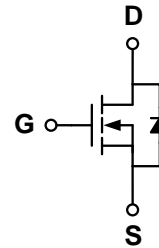

Marking and pin assignment

SOT-23-3L
(TOP VIEW)

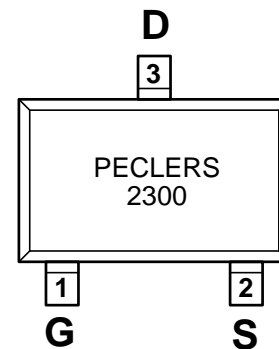

Ordering Information

Part Number	Storage Temperature	Package	Devices Per Reel
PECN2300MR	-55°C to +150°C	SOT-23-3L	3000

Absolute Maximum Ratings (TA=25°C unless otherwise noted)

parameter	symbol	limit	unit	
Drain-source voltage	V_{DS}	20	V	
Gate-source voltage	V_{GS}	±12	V	
Continuous Drain Current	I_D	$T_A = 25^\circ C$	5	A
		$T_A = 70^\circ C$	4	
Pulsed Drain Current ^C	I_{DM}	25	A	
Drain-source Diode forward current	I_S	2	A	
Maximum power dissipation	P_D	$T_A = 25^\circ C$	1.4	W
		$T_A = 70^\circ C$	0.9	
Operating junction Temperature range	T_j	-55—150	°C	

Electrical Characteristics (TA=25°C unless otherwise noted)

Parameter	Symbol	Condition	Min	Typ	Max	Unit
OFF Characteristics						
Drain-source breakdown voltage	BV_{DSS}	$V_{GS}=0V, I_D=250\mu A$	20	-	-	V
Zero gate voltage drain current	I_{DSS}	$V_{DS}=20V, V_{GS}=0V$	-	-	1	μA
Gate-body leakage	I_{GSS}	$V_{DS}=0V, V_{GS}=\pm 12V$	-	-	± 100	nA
ON Characteristics						
Gate threshold voltage	$V_{GS(th)}$	$V_{DS}=V_{GS}, I_D=250\mu A$	0.45	0.66	1.3	V
Drain-source on-state resistance	$R_{DS(ON)}$	$V_{GS}=4.5V, I_D=5A$	-	24	30	m Ω
		$V_{GS}=2.5V, I_D=3A$		30	36	
Forward transconductance	g_{fs}	$V_{GS}=5V, I_D=4A$	-	10	-	S
Dynamic Characteristics						
Input capacitance	C_{ISS}	$V_{DS}=8V, V_{GS}=0V$ $f=1.0MHz$	-	525	-	pF
Output capacitance	C_{OSS}		-	95	-	
Reverse transfer capacitance	C_{RSS}		-	75	-	
Switching Characteristics						
Turn-on delay time	$t_{D(ON)}$	$V_{DS}=10V$ $I_D=1A$ $V_{GS}=4V$ $R_{GEN}=10ohm$	-	3	-	ns
Rise time	t_r		-	7.5	-	
Turn-off delay time	$t_{D(OFF)}$		-	20	-	
Fall time	t_f		-	6	-	
Total gate charge	Q_g	$V_{DS}=10V, I_D=4A$ $V_{GS}=4.5V$	-	12.5	-	nC
Gate-source charge	Q_{gs}		-	1	-	
Gate-drain charge	Q_{gd}		-	2	-	
DRAIN-SOURCE DIODE CHARACTERISTICS						
Diode forward voltage	V_{SD}	$V_{GS}=0V, I_s=1A$	-	0.76	1.16	V

Thermal Characteristics

Parameter	Symbol	Typ.	Max.	Unit
Maximum Junction-to-Ambient ^A	$R_{\theta JA}$	70	90	°C/W
Maximum Junction-to-Ambient ^{A D}		Steady-State	100	
Maximum Junction-to-Lead	$R_{\theta JL}$	62	80	

A. The value of $R_{\theta JA}$ is measured with the device mounted on 1in² FR-4 board with 2oz. Copper, in a still air environment with $T_A=25^\circ C$. The value in any given application depends on the user's specific board design.

B. The power dissipation PD is based on $T_{J(MAX)}=150^\circ C$, using $\leq 10s$ junction-to-ambient thermal resistance.

C. Repetitive rating, pulse width limited by jun

Package Information

- SOT-23-3L

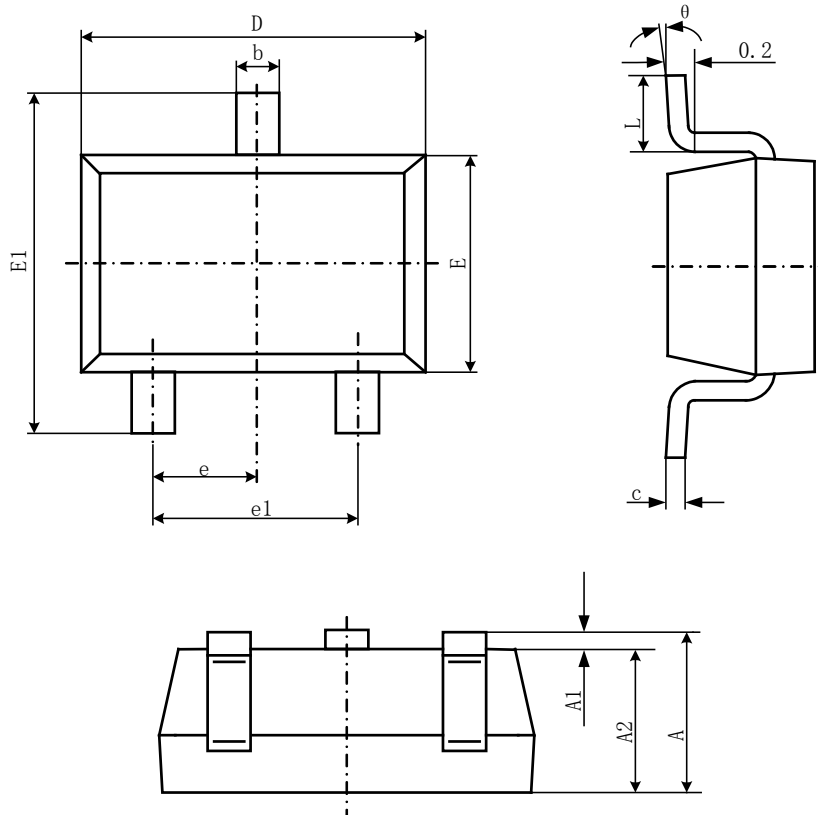

Symbol	Dimensions In Millimeters		Dimensions In Inches	
	Min	Max	Min	Max
A	1.050	1.250	0.041	0.049
A1	0.000	0.100	0.000	0.004
A2	1.050	1.150	0.041	0.045
b	0.300	0.500	0.012	0.020
c	0.100	0.200	0.004	0.008
D	2.820	3.020	0.111	0.119
E	1.500	1.700	0.059	0.067
E1	2.650	2.950	0.104	0.116
e	0.950(BSC)		0.037(BSC)	
e1	1.800	2.000	0.071	0.079
L	0.300	0.600	0.012	0.024
θ	0°	8°	0°	8°