

20V P-Channel Enhancement Mode MOSFET

Description

The PECN2309EFR uses advanced trench technology to provide excellent $R_{DS(ON)}$, low gate charge and operation with gate voltages as low as 1.8V. This device is suitable for use as a load switch or in PWM applications.

General Features

- ◆ $V_{DS} = -20V$, $I_D = -2A$
 $R_{DS(ON)}(Typ.) = 70m\Omega$ @ $V_{GS} = -2.5V$
 $R_{DS(ON)}(Typ.) = 60m\Omega$ @ $V_{GS} = -4.5V$
- ◆ High power and current handling capability
- ◆ Lead free product is acquired
- ◆ Surface mount package
- ◆ ESD Rating: 2500V HBM

Application

- ◆ PWM applications
- ◆ Load switch

Package

- ◆ SOT-363



Schematic diagram

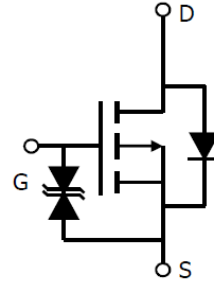

Marking and pin assignment

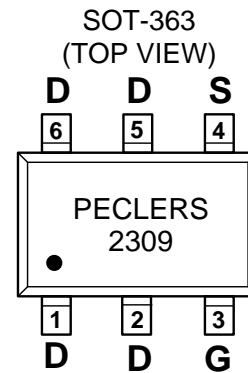

Ordering Information

Part Number	Storage Temperature	Package	Devices Per Reel
PECN2309EFR	-55°C to +150°C	SOT-363	3000

Absolute Maximum Ratings (TA=25°C unless otherwise noted)

parameter	symbol	limit	unit
Drain-source voltage	V_{DS}	-20	V
Gate-source voltage	V_{GS}	±8	V
Drain current-continuous ^a @ $T_j = 125^\circ C$ -pulse ^b	I_D	-2	A
	I_{DM}	-8	A
Maximum power dissipation	P_D	$T_A = 25^\circ C$	1.6
		$T_A = 70^\circ C$	1.4
Operating junction Temperature range	T_j	-55—150	°C

Electrical Characteristics (TA=25°C unless otherwise noted)

Parameter	Symbol	Condition	Min	Typ	Max	Unit
OFF Characteristics						
Drain-source breakdown voltage	BV_{DSS}	$V_{GS}=0V, I_D=-250\mu A$	-20	-	-	V
Zero gate voltage drain current	I_{DSS}	$V_{DS}=-20V, V_{GS}=0V$	-	-	-1	μA
Gate-body leakage	I_{GSS}	$V_{DS}=0V, V_{GS}=\pm 8V$	-	-	± 10	μA
ON Characteristics						
Gate threshold voltage	$V_{GS(th)}$	$V_{DS}=V_{GS}, I_D=-250\mu A$	-0.4	-0.59	-0.9	V
Drain-source on-state resistance	$R_{DS(on)}$	$V_{GS}=-4.5V, I_D=-4A$	-	45	55	m Ω
		$V_{GS}=-2.5V, I_D=-3A$	-	55	65	
Forward transconductance	gfs	$V_{GS}=-5V, I_D=-4A$	8	-	-	S
Dynamic Characteristics						
Input capacitance	C_{ISS}	$V_{DS}=-10V, V_{GS}=0V$ $f=1.0MHz$	-	751	-	pF
Output capacitance	C_{OSS}		-	115	-	
Reverse transfer capacitance	C_{RSS}		-	80	-	
Switching Characteristics						
Turn-on delay time	$t_{D(on)}$	$V_{DD}=-10V$ $I_D=-2.8A$ $V_{GEN}=-4.5V$ $R_L=10ohm$ $R_{GEN}=-60ohm$	-	13	-	ns
Rise time	t_r		-	9	-	
Turn-off delay time	$t_{D(off)}$		-	19	-	
Fall time	t_f		-	29	-	
Total gate charge	Qg	$V_{DS}=-10V, I_D=-3A$ $V_{GS}=-4.5V$	-	9.3	-	nC
Gate-source charge	Qgs		-	1	-	
Gate-drain charge	Qgd		-	2.2	-	
DRAIN-SOURCE DIODE CHARACTERISTICS						
Diode forward voltage	V_{SD}	$V_{GS}=0V, I_S=-1.25A$	-	-0.81	-1.2	V

Notes:

- surface mounted on FR4 board, $t \leq 10sec$
- pulse test: pulse width $\leq 300\mu s$, duty $\leq 2\%$
- guaranteed by design, not subject to production testing

Thermal Characteristics

Thermal Resistance junction-to ambient	$R_{\theta JA}$	80	$^{\circ}C/W$
--	-----------------	----	---------------

Gate Charge Test Circuit & Waveform

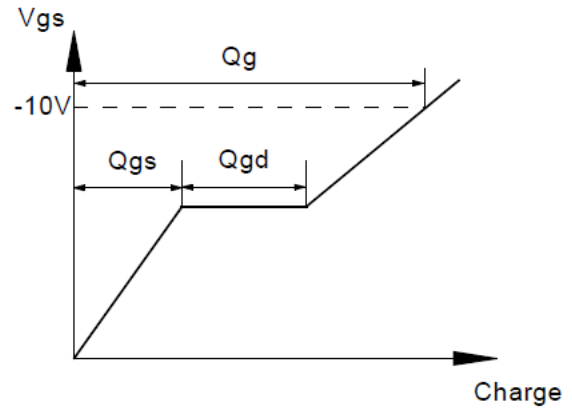
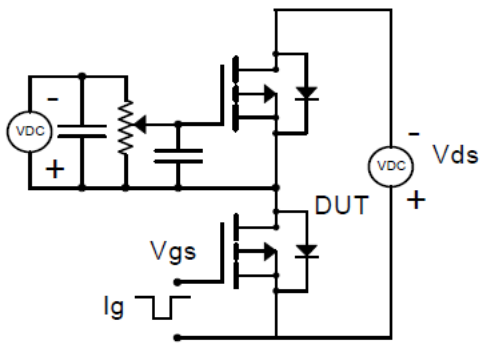

Resistive Switching Test Circuit & Waveforms

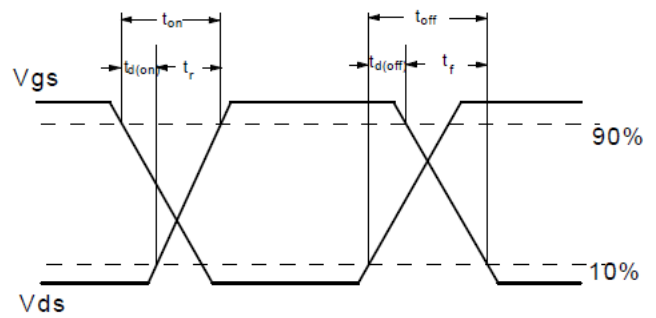
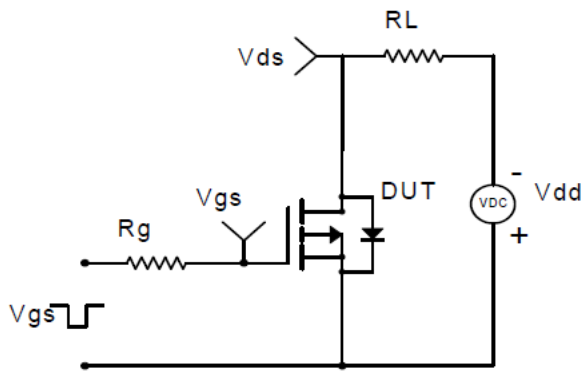

Diode Recovery Test Circuit & Waveforms

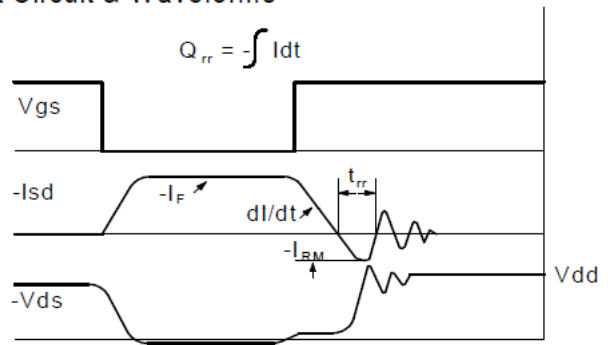
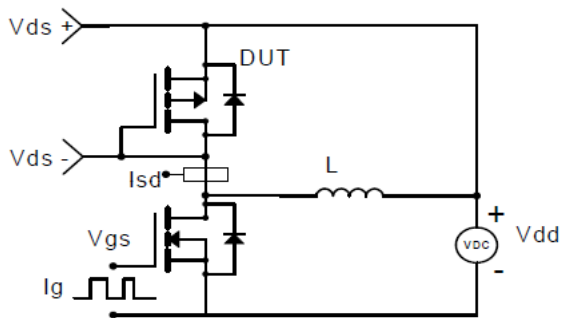

Package Information

- SOT-363

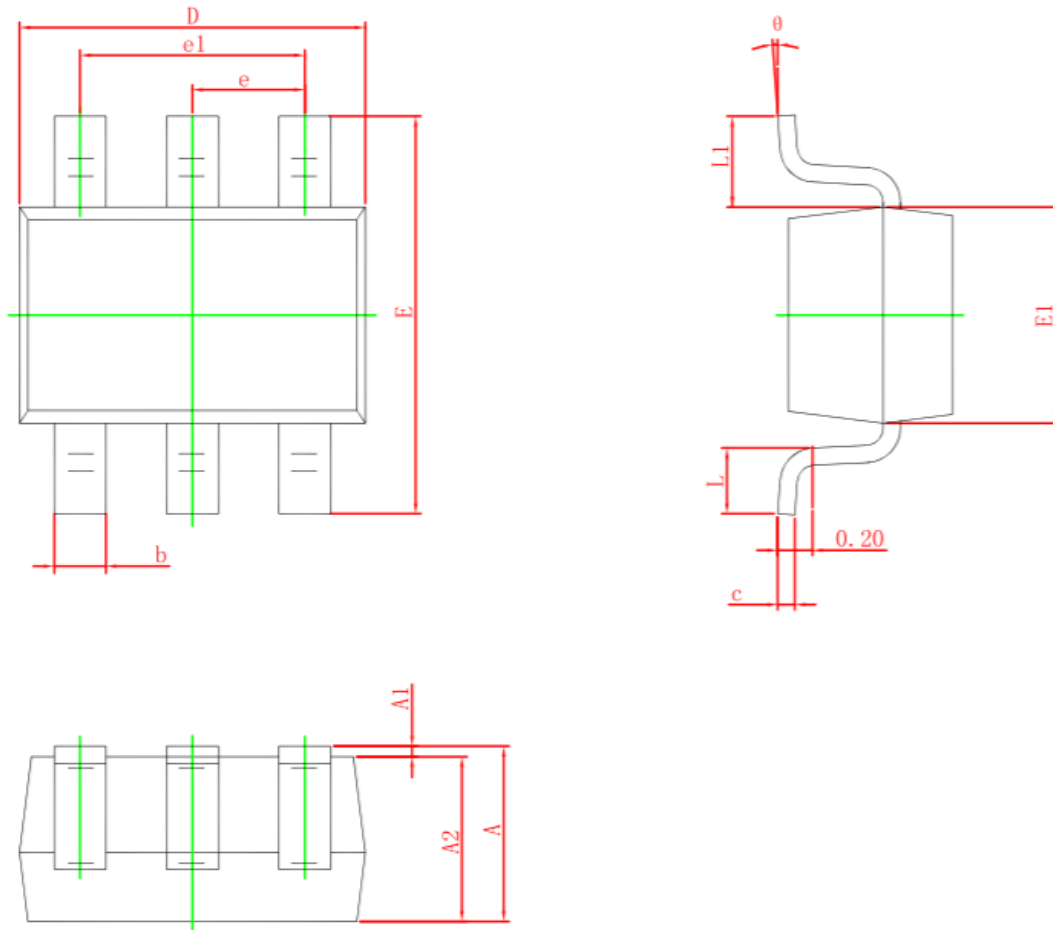

Symbol	Dimensions In Millimeters		Dimensions In Inches	
	Min.	Max.	Min.	Max.
A	0.900	1.100	0.035	0.043
A1	0.000	0.100	0.000	0.004
A2	0.900	1.000	0.035	0.039
b	0.150	0.350	0.006	0.014
c	0.080	0.150	0.003	0.006
D	2.000	2.200	0.079	0.087
E	2.150	2.450	0.085	0.096
E1	1.150	1.350	0.045	0.053
e	0.650 TYP.		0.026 TYP.	
e1	1.200	1.400	0.047	0.055
L	0.260	0.460	0.010	0.018
L1	0.525 REF.		0.021 REF.	
θ	0°	8°	0°	8°