

100V N-Channel Enhancement Mode MOSFET

Description

The PECN2N10MR uses advanced trench technology to provide excellent $R_{DS(ON)}$, low gate charge and high density cell Design for ultra low on- resistance. This device is suitable for use as a load switch or in PWM applications.

General Features

- ◆ $V_{DS} = 100V$, $I_D = 2A$
 $R_{DS(ON)}(Typ.) = 220m\Omega$ @ $V_{GS} = 10V$
 $R_{DS(ON)}(Typ.) = 240m\Omega$ @ $V_{GS} = 4.5V$
- ◆ High power and current handing capability
- ◆ Lead free product is acquired
- ◆ Surface mount package

Application

- ◆ PWM applications
- ◆ Load switch

Package

- ◆ SOT-23-3L



Schematic diagram

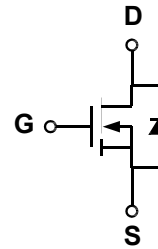

Marking and pin assignment

SOT-23-3L
(TOP VIEW)

D
3

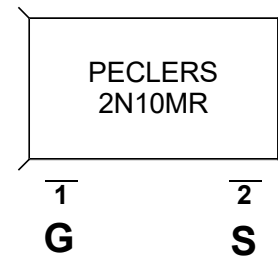

Ordering Information

Part Number	Storage Temperature	Package	Devices Per Reel
PECN2N10MR	-55°C to +150°C	SOT-23-3L	3000

Absolute Maximum Ratings (TA=25°C unless otherwise noted)

parameter	symbol	limit	unit
Drain-source voltage	V_{DS}	100	V
Gate-source voltage	V_{GS}	±20	V
Drain current-continuous@Tj=125°C -pulse d^C	I_D	2	A
	I_{DM}	8	A
Drain-source Diode forward current	I_S	2	A
Avalanche Current	I_{AS}	4.8	A
Single Pulse Avalanche Energy	E_{AS}	6.3	mJ
Maximum power dissipation ^B	P_D	1.25	W
Operating junction Temperature range	T_j	-55—150	°C

Electrical Characteristics (TA=25°C unless otherwise noted)

Parameter	Symbol	Condition	Min	Typ	Max	Unit
OFF Characteristics						
Drain-source breakdown voltage	BV_{DSS}	$V_{GS}=0V, I_D=250\mu A$	100	-	-	V
Zero gate voltage drain current	I_{DSS}	$V_{DS}=100V, V_{GS}=0V$	-	-	1	μA
Gate-body leakage	I_{GSS}	$V_{DS}=0V, V_{GS}=\pm 20V$	-	-	± 100	nA
ON Characteristics						
Gate threshold voltage	$V_{GS(th)}$	$V_{DS}=V_{GS}, I_D=250\mu A$	1.2	1.9	2.5	V
Drain-source on-state resistance	$R_{DS(ON)}$	$V_{GS}=10V, I_D=2A$	-	220	240	m Ω
		$V_{GS}=4.5V, I_D=2A$		240	260	
Forward transconductance	G_{FS}	$V_{DS}=5V, I_D=1A$	1	-	-	S
Dynamic Characteristics						
Input capacitance	C_{ISS}	$V_{DS}=50V, V_{GS}=0V$ $f=1.0MHz$	-	190	-	pF
Output capacitance	C_{OSS}		-	22	-	
Reverse transfer capacitance	C_{RSS}		-	13	-	
Switching Characteristics						
Turn-on delay time	$t_{D(ON)}$	$V_{DD}=50V$ $R_L=39\text{ ohm}$ $V_{GS}=10V$ $R_G=1\text{ohm}$	-	6	-	ns
Rise time	t_r		-	10	-	
Turn-off delay time	$t_{D(OFF)}$		-	10	-	
Fall time	t_f		-	6	-	
Total gate charge	Q_g	$V_{DS}=50V$ $I_D=1.3A$ $V_{GS}=10V$	-	5.2	-	nC
Gate-source charge	Q_{gs}		-	0.75	-	
Gate-drain charge	Q_{gd}		-	1.4	-	
DRAIN-SOURCE DIODE CHARACTERISTICS						
Diode forward voltage	V_{SD}	$V_{GS}=0V, I_S=2A$	-	0.76	1.16	V

Thermal Characteristics

Parameter	Symbol	Typ.	Max.	Unit
Maximum Junction-to-Ambient ^A	$t \leq 10s$	70	90	°C/W
Maximum Junction-to-Ambient ^{A D}	Steady-State	100	125	
Maximum Junction-to-Lead	Steady-State	62	80	

A. The value of $R_{\theta JA}$ is measured with the device mounted on 1in² FR-4 board with 2oz. Copper, in a still air environment with $T_A = 25^\circ C$. The value in any given application depends on the user's specific board design.

B. The power dissipation PD is based on $T_{J(MAX)} = 150^\circ C$, using $\leq 10s$ junction-to-ambient thermal resistance.

C. Repetitive rating, pulse width limited by junction temperature $T_{J(MAX)} = 150^\circ C$. Ratings are based on low frequency and duty cycles to keep initial $T_J = 25^\circ C$.

D. The $R_{\theta JA}$ is the sum of the thermal impedance from junction to lead $R_{\theta JL}$ and lead to ambient.

Typical Performance Characteristics

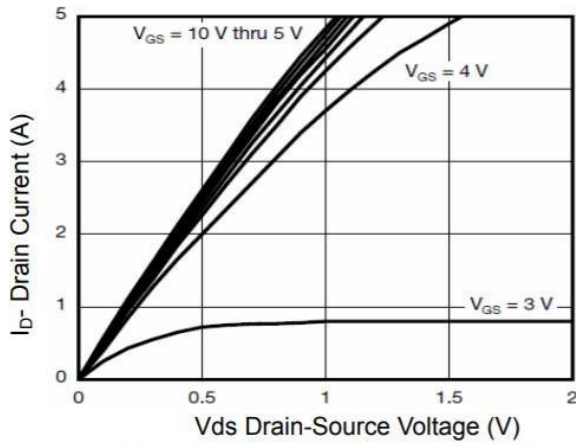

Figure 1 Output Characteristics

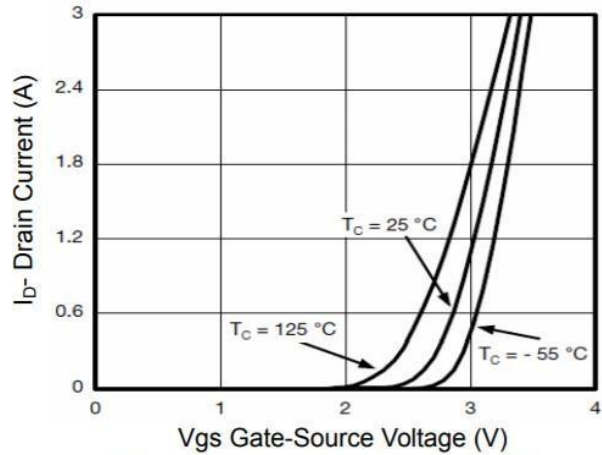

Figure 2 Transfer Characteristics

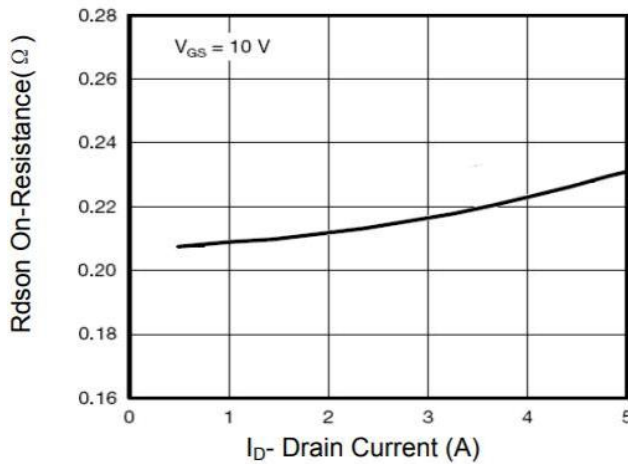

Figure 3 Rdson- Drain Current

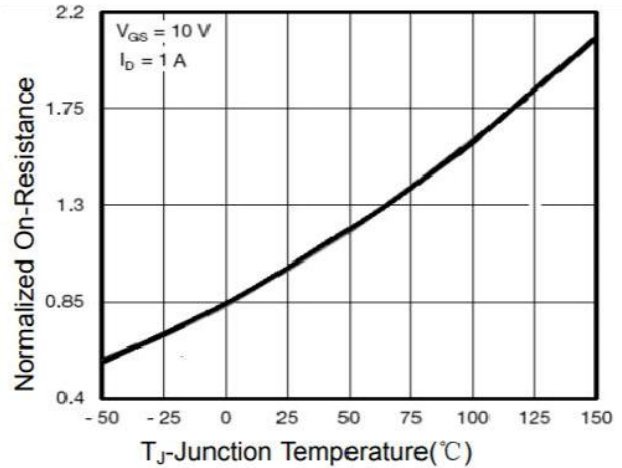

Figure 4 Rdson-Junction Temperature

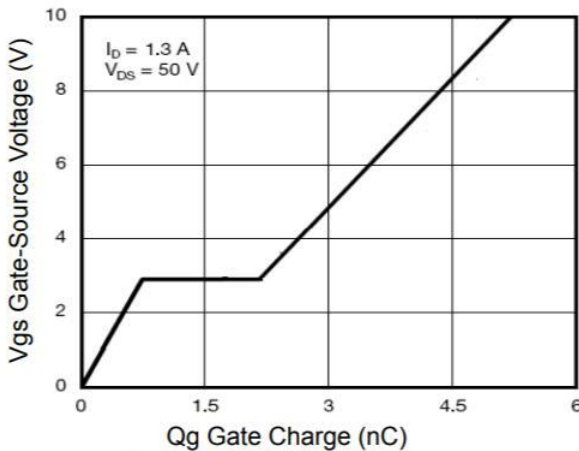

Figure 5 Gate Charge

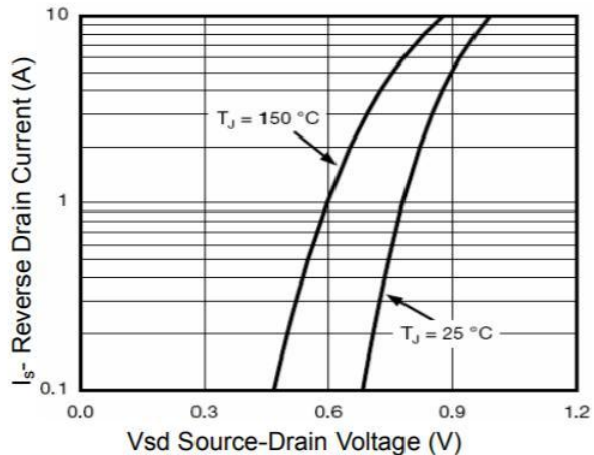

Figure 6 Source- Drain Diode Forward

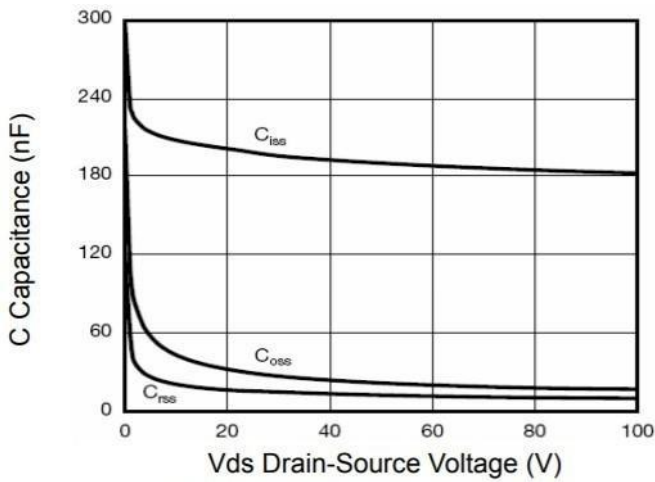

Figure 7 Capacitance vs Vds

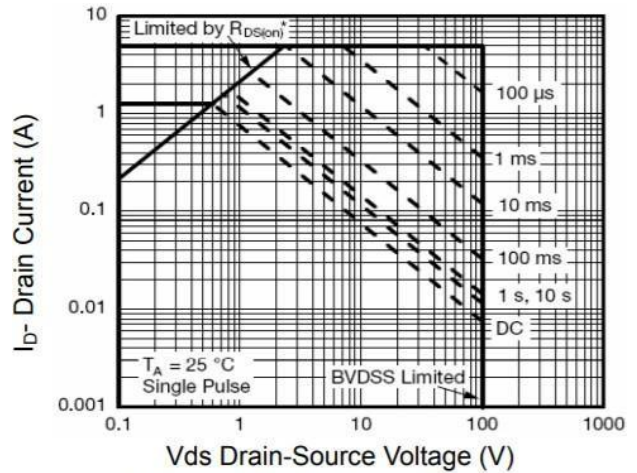

Figure 8 Safe Operation Area

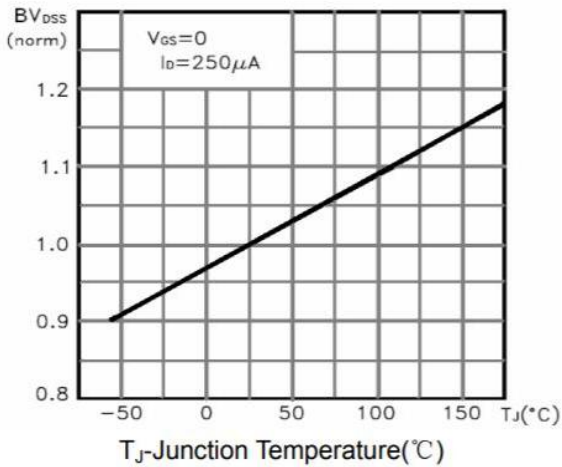

Figure 9 BV_{DSS} vs Junction Temperature

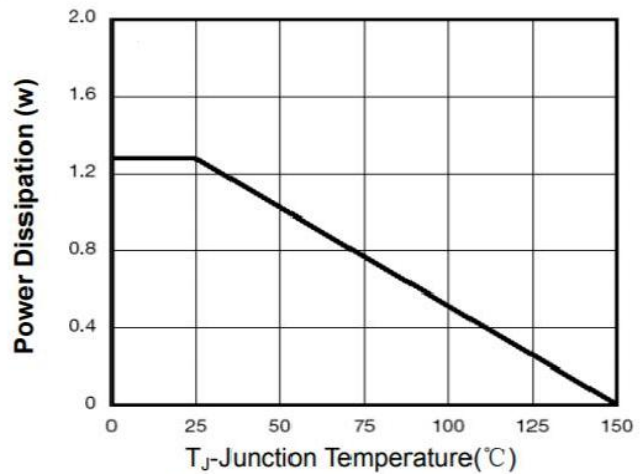

Figure 10 Power De-ratin

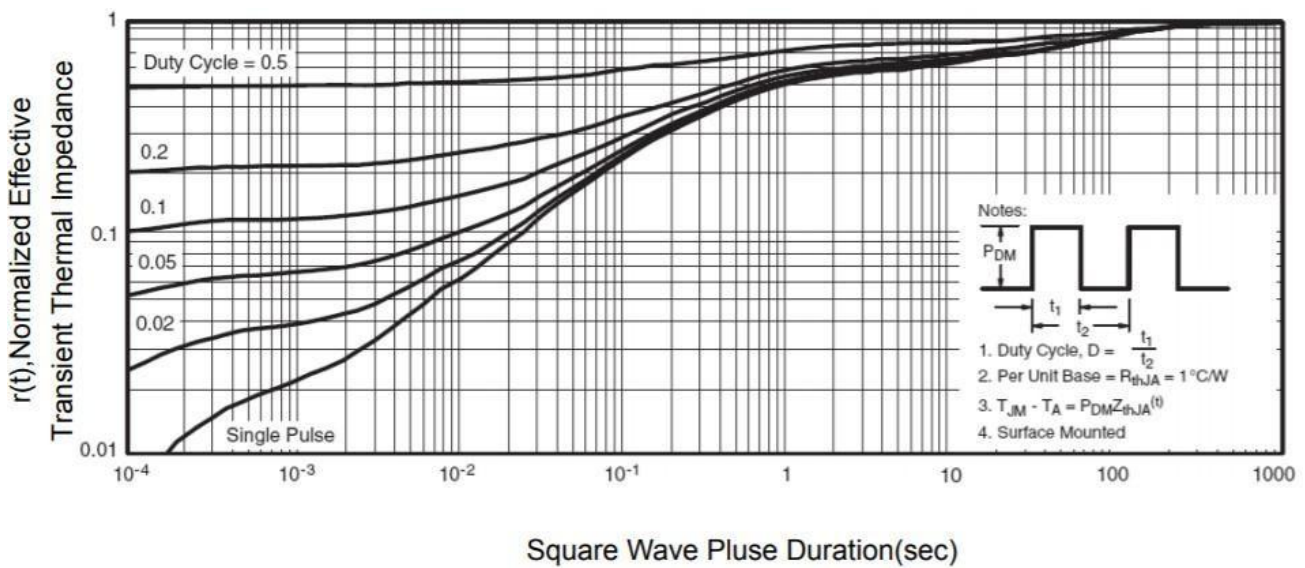
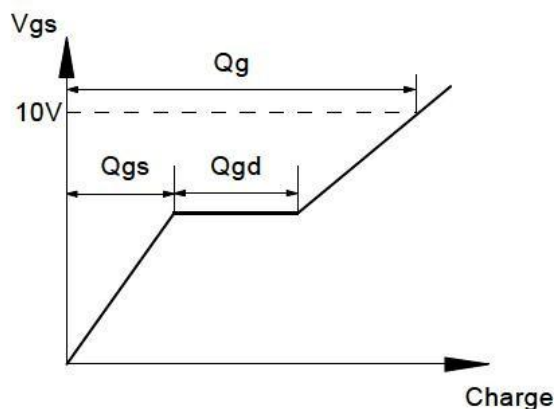
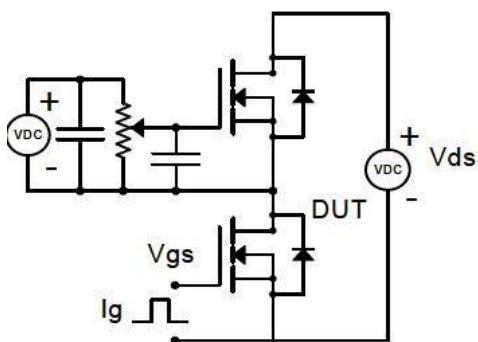

Figure 11 Normalized Maximum Transient Thermal Impedance

Gate Charge Test Circuit & Waveform



Resistive Switching Test Circuit & Waveforms

Resistive Switching Test Circuit & Waveforms

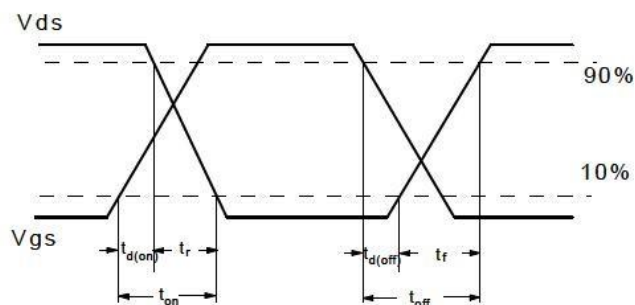
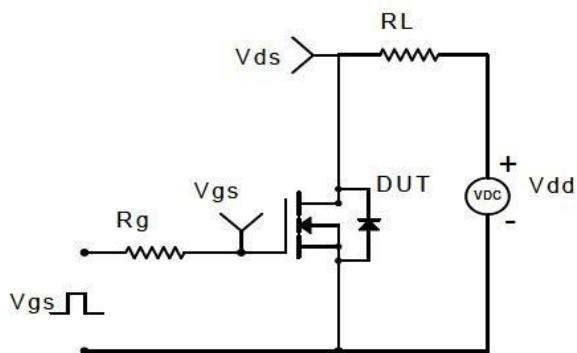

Diode Recovery Test Circuit & Waveforms

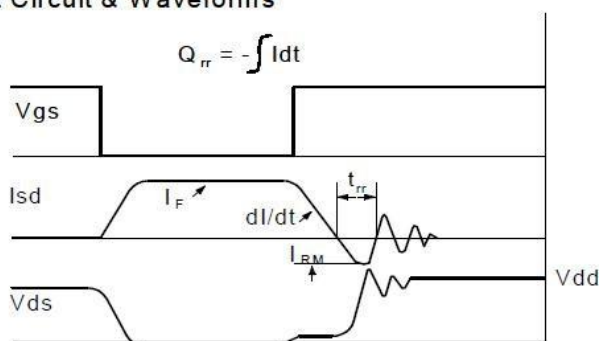
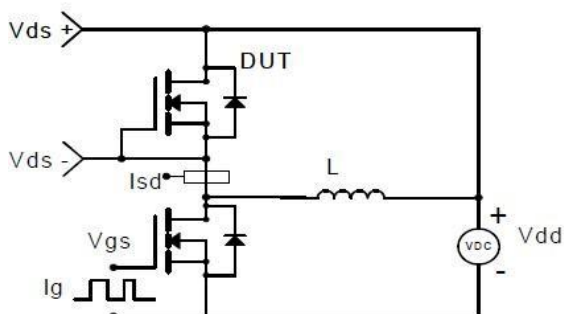

Package Information

- SOT-23-3L

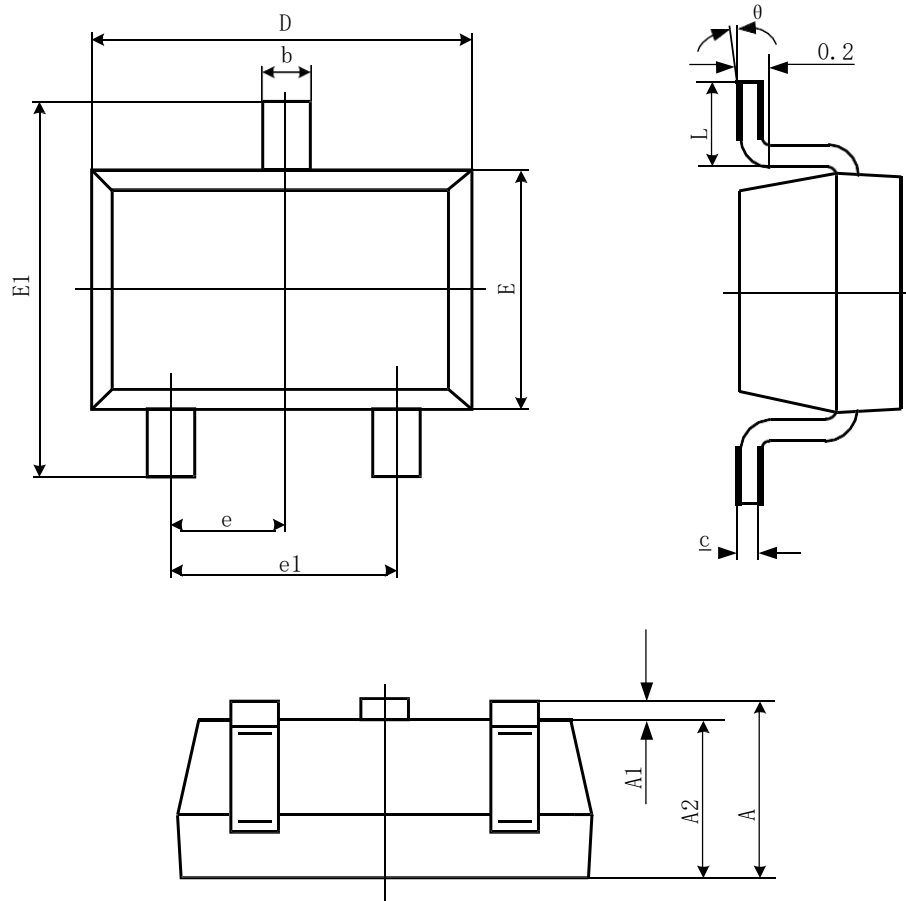

Symbol	Dimensions In Millimeters		Dimensions In Inches	
	Min	Max	Min	Max
A	1.050	1.250	0.041	0.049
A1	0.000	0.100	0.000	0.004
A2	1.050	1.150	0.041	0.045
b	0.300	0.500	0.012	0.020
c	0.100	0.200	0.004	0.008
D	2.820	3.020	0.111	0.119
E	1.500	1.700	0.059	0.067
E1	2.650	2.950	0.104	0.116
e	0.950(BSC)		0.037(BSC)	
e1	1.800	2.000	0.071	0.079
L	0.300	0.600	0.012	0.024
θ	0°	8°	0°	8°