

## N-Channel Enhancement Mode MOSFET

### Description

The PECN3008 uses advanced trench technology to provide excellent  $R_{DS(ON)}$ , low gate charge and high density cell Design for ultra low on-resistance. This device is suitable for use as a load switch or in PWM applications.

### General Features

- ◆  $V_{DS} = 30V$ ,  $I_D = 8A$   
 $R_{DS(ON)}(Typ.) = 17.5m\Omega$  @  $V_{GS} = 4.5V$   
 $R_{DS(ON)}(Typ.) = 14.5m\Omega$  @  $V_{GS} = 10V$
- ◆ High power and current handing capability
- ◆ Lead free product is acquired
- ◆ Surface mount package

### Application

- ◆ PWM applications
- ◆ Load switch

### Package

- ◆ DFN2\*2-6L-B

*100% UIS TESTED!*  
*100%  $\Delta V_{ds}$  TESTED!*

### Schematic diagram

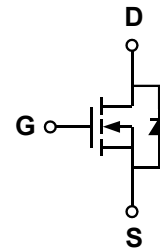

### Marking and pin assignment

**DFN2\*2-6L-B**

(Thickness 0.55mm)

Top View

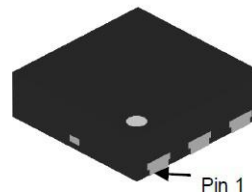

Bottom View

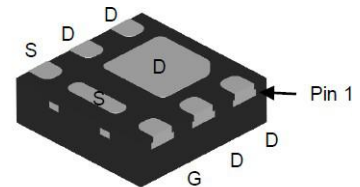

PECN Natlinear Power  
 3008--- PECN3008



### Ordering Information

Part Number	Storage Temperature	Package	Devices Per Reel
PECN3008D R-G	-55°C to +150°C	DFN2*2-6L-B	4000

### Absolute Maximum Ratings (TA=25°C unless otherwise noted)

parameter	symbol	limit	unit
Drain-source voltage	$V_{DS}$	30	V
Gate-source voltage	$V_{GS}$	$\pm 12$	V
Drain current-continuous <sup>a</sup> @Tj=125°C -pulse <sup>b</sup>	$I_D$	8	A
	$I_{DM}$	32	A
Drain-source Diode forward current	$I_S$	8	A
Maximum power dissipation	$P_D$	18	W
Operating junction Temperature range	$T_j$	-55—150	°C

## Electrical Characteristics (TA=25°C unless otherwise noted)

Parameter	Symbol	Condition	Min	Typ	Max	Unit
<b>OFF Characteristics</b>						
Drain-source breakdown voltage	$BV_{DSS}$	$V_{GS}=0V, I_D=250\mu A$	30	-	-	V
Zero gate voltage drain current	$I_{DSS}$	$V_{DS}=30V, V_{GS}=0V$	-	-	1	$\mu A$
Gate-body leakage	$I_{GSS}$	$V_{DS}=0V, V_{GS}=\pm 12V$	-	-	$\pm 100$	nA
<b>ON Characteristics</b>						
Gate threshold voltage	$V_{GS(th)}$	$V_{DS}=V_{GS}, I_D=250\mu A$	0.5	0.9	1.3	V
Drain-source on-state resistance	$R_{DS(ON)}$	$V_{GS}=10V, I_D=8A$	-	14.5	18	m $\Omega$
		$V_{GS}=4.5V, I_D=6A$	-	17.5	23	
		$V_{GS}=2.5V, I_D=4A$	-	31	37	
Forward transconductance	gfs	$V_{GS}=5V, I_D=8A$	-	33	-	S
<b>Dynamic Characteristics</b>						
IPECNut capacitance	$C_{ISS}$	$V_{DS}=15V, V_{GS}=0V$ $f=1.0MHz$	-	813	-	pF
Output capacitance	$C_{OSS}$		-	98	-	
Reverse transfer capacitance	$C_{RSS}$		-	56	-	
<b>Switching Characteristics</b>						
Turn-on delay time	$t_{D(ON)}$	$V_{DS}=15V$ $V_{GS}=10V$ $R_L=2.6\ ohm$ $R_{GEN}=3ohm$	-	3	-	ns
Rise time	tr		-	3	-	
Turn-off delay time	$t_{D(OFF)}$		-	26	-	
Fall time	tf		-	3.6	-	
Total gate charge	Qg	$V_{DS}=15V, I_D=8A$ $V_{GS}=4.5V$	-	8	12	nC
Gate-source charge	Qgs		-	1.2	-	
Gate-drain charge	Qgd		-	2.6	-	
<b>DRAIN-SOURCE DIODE CHARACTERISTICS</b>						
Diode forward voltage	$V_{SD}$	$V_{GS}=0V, I_S=1A$	-	0.76	1.16	V

### Notes:

- surface mounted on FR4 board,  $t \leq 10sec$
- pulse test: pulse width  $\leq 300\mu s$ , duty  $\leq 2\%$
- guaranteed by design, not subject to production testing

## Thermal Characteristics

Thermal Resistance junction-to ambient	Rth JA	100	$^{\circ}C/W$
--	--------	-----	---------------

## Gate Charge Test Circuit & Waveform

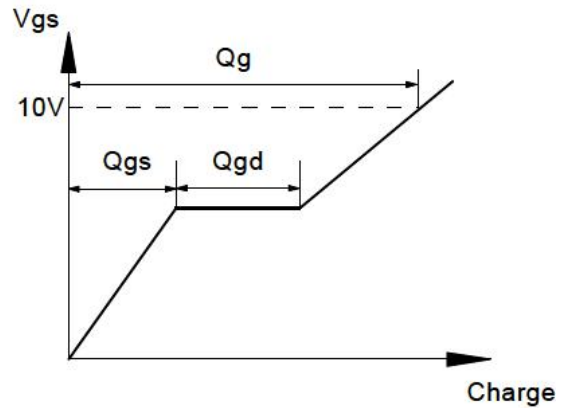
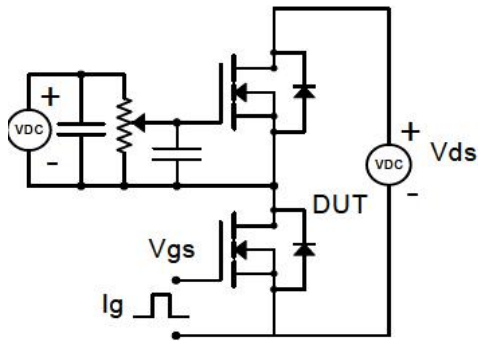

## Resistive Switching Test Circuit & Waveforms

### Resistive Switching Test Circuit & Waveforms

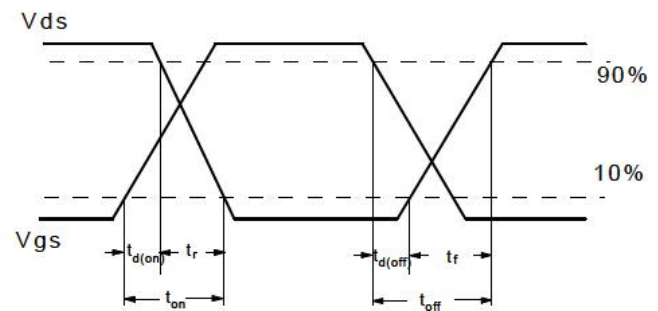
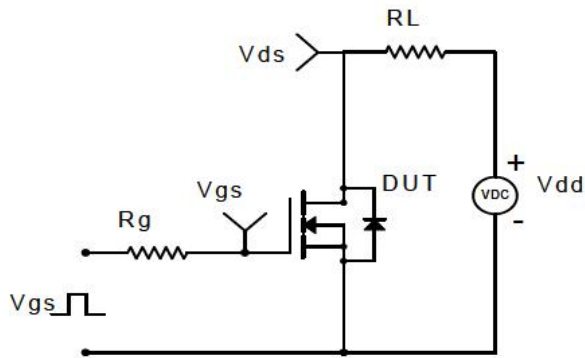

## Diode Recovery Test Circuit & Waveforms

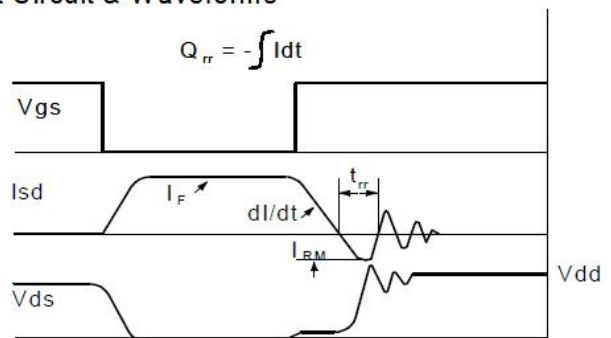
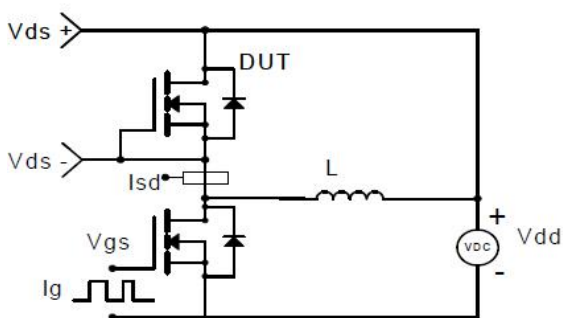

## Package Information

- DFN2\*2-6L-B

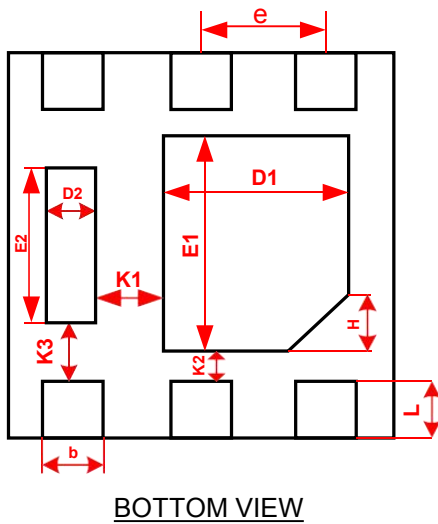
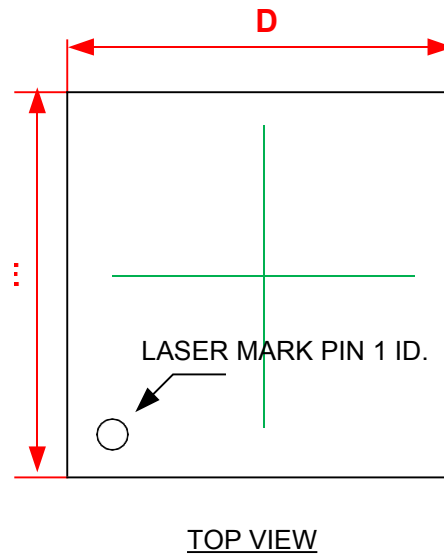
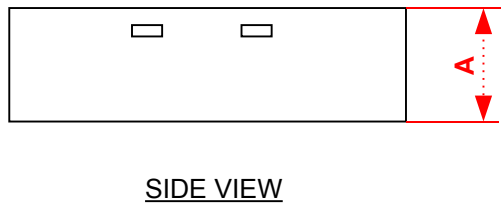
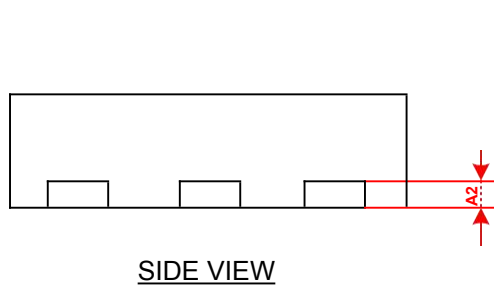

Common Dimension (mm)			
PKG	DFN2020-6L-B		
SYMBOL	MIN.	MON.	MAX.
A	0.527	0.552	0.577
A2		0.127REF	
b	0.25	0.30	0.35
D	1.90	2.00	2.10
E	1.90	2.00	2.10
D1	0.85	0.95	1.05
E1	1.05	1.15	1.25
D2	0.20	0.25	0.30
E2	0.69	0.79	0.89
e	0.55	0.65	0.75
H	0.25	0.30	0.35
K1	0.25MIN		
K2	0.15MIN		
K3	0.20MIN		
L	0.20	0.25	0.30

## Tape and Reel

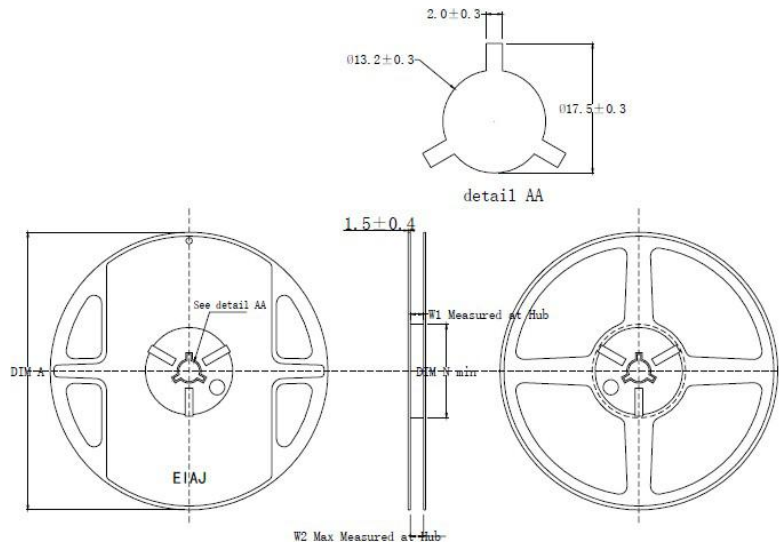

PRODUCT SPECIFICATIONS				
TYPE WIDTH	$\phi A$	$\phi N$	W1 (Min)	W2 (Max)
8MM	$178 \pm 2.0$	$60 \pm 1.0$	8.4	11.4
12MM	$178 \pm 2.0$	$60 \pm 1.0$	12.4	15.4

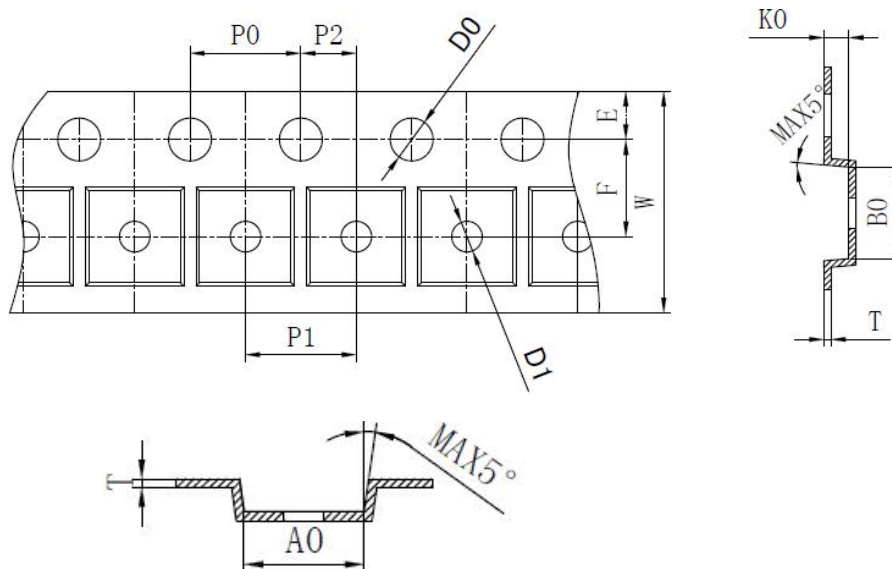

SYMBOL	A0	B0	K0	P0	P1	P2
SPEC	$2.20 \pm 0.05$	$2.20 \pm 0.05$	$0.75 \pm 0.10$	$4.00 \pm 0.10$	$4.00 \pm 0.10$	$2.00 \pm 0.05$
SYMBOL	T	E	F	D0	D1	W
SPEC	$0.20 \pm 0.03$	$1.75 \pm 0.10$	$3.50 \pm 0.05$	$1.55 \pm 0.05$	$1.00^{+0.10}_{-0}$	$8.00^{+0.20}_{-0.10}$