

### 30V P-Channel Enhancement Mode MOSFET

#### Description

The PECN3401VR uses advanced trench technology to provide excellent  $R_{DS(ON)}$ , low gate charge and operation with gate voltages as low as 2.5V. This device is suitable for use as a load switch or in PWM applications.

#### General Features

- ◆  $V_{DS} = -30V$ ,  $I_D = -4.2A$   
 $R_{DS(ON)}(Typ.) = 53m\Omega$  @  $V_{GS} = -4.5V$   
 $R_{DS(ON)}(Typ.) = 73m\Omega$  @  $V_{GS} = -2.5V$
- ◆ High power and current handling capability
- ◆ Lead free product is acquired
- ◆ Surface mount package

#### Application

- ◆ PWM applications
- ◆ Load switch

#### Package

- ◆ SOT-23



#### Schematic diagram

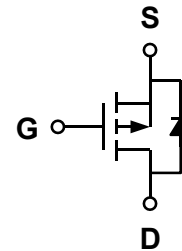

#### Marking and pin assignment

SOT-23  
(TOP VIEW)

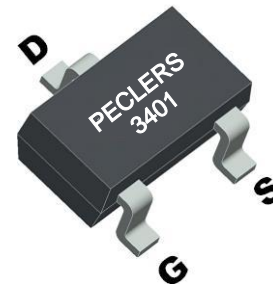

#### Ordering Information

Part Number	Storage Temperature	Package	Devices Per Reel
PECN3401VR	-55°C to +150°C	SOT-23	3000

#### Absolute Maximum Ratings (TA=25°C unless otherwise noted)

parameter	symbol	limit	unit	
Drain-source voltage	$V_{DS}$	-30	V	
Gate-source voltage	$V_{GS}$	±12	V	
Continuous Drain Current (TJ = 150 °C)	$I_D$	$T_C = 25^\circ C$	-4.2	A
		$T_C = 70^\circ C$	-3.5	
		$T_A = 25^\circ C$	-3.7 <sup>b,c</sup>	
		$T_A = 70^\circ C$	-2.9 <sup>b,c</sup>	
Continuous Source-Drain Diode Current	$I_S$	$T_C = 25^\circ C$	-1.4	
		$T_A = 25^\circ C$	-1 <sup>b,c</sup>	
Pulsed Drain Current (t = 300 μs)	$I_{DM}$	-12.8		

Maximum power dissipation	$T_C=25^{\circ}\text{C}$	$P_D$	1.7	W
	$T_C=70^{\circ}\text{C}$		1.1	
	$T_A=25^{\circ}\text{C}$		1 <sup>b,c</sup>	
	$T_A=70^{\circ}\text{C}$		0.6 <sup>b,c</sup>	
Operating Junction and Storage Temperature Range		$T_J, T_{STG}$	-55—150	$^{\circ}\text{C}$

### Thermal Characteristics

Parameter	Symbol	Typical	Maximum	Unit	
Maximum Junction-to-Ambient <sup>b, d</sup>	$t \leq 5 \text{ s}$	$R_{\theta JA}$	100	130	$^{\circ}\text{C/W}$
Maximum Junction-to-Foot (Drain)	Steady State	$R_{\theta JF}$	60	75	

Notes:

- a.  $T_C = 25^{\circ}\text{C}$ .
- b. Surface mounted on 1" x 1" FR4 board.
- c.  $t = 5 \text{ s}$ .
- d. Maximum under steady state conditions is  $175^{\circ}\text{C/W}$ .

### Electrical Characteristics ( $T_A=25^{\circ}\text{C}$ unless otherwise noted)

Parameter	Symbol	Condition	Min	Typ	Max	Unit
<b>OFF Characteristics</b>						
Drain-source breakdown voltage	$BV_{DSS}$	$V_{GS}=0\text{V}, I_D=-250\mu\text{A}$	-30	-	-	V
Zero gate voltage drain current	$I_{DSS}$	$V_{DS}=-30\text{V}, V_{GS}=0\text{V}$	-	-	-1	$\mu\text{A}$
Gate-body leakage	$I_{GSS}$	$V_{DS}=0\text{V}, V_{GS}=\pm 12\text{V}$	-	-	$\pm 100$	nA
<b>ON Characteristics</b>						
Gate threshold voltage	$V_{GS(th)}$	$V_{DS}=V_{GS}, I_D=-250\mu\text{A}$	-0.5	-0.83	-1.3	V
Drain-source on-state resistance	$R_{DS(ON)}$	$V_{GS}=-4.5\text{V}, I_D=-4\text{A}$	-	53	65	m $\Omega$
		$V_{GS}=-2.5\text{V}, I_D=-1\text{A}$	-	73	85	
Forward transconductance	$g_{fs}$	$V_{DS}=-5\text{V}, I_D=-4\text{A}$	-	11	-	S
<b>Dynamic Characteristics</b>						
Input capacitance	$C_{ISS}$	$V_{DS}=-15\text{V}, V_{GS}=0\text{V}$ $f=1.0\text{MHz}$	-	880	-	pF
Output capacitance	$C_{OSS}$		-	105	-	
Reverse transfer capacitance	$C_{RSS}$		-	65	-	
<b>Switching Characteristics</b>						
Turn-on delay time	$t_{D(ON)}$	$V_{DD}=-15\text{V}$ $I_D=-4\text{A}$ $V_{GEN}=-10\text{V}$ $R_L=3.6\text{ohm}$ $R_{GEN}=6\text{ohm}$	-	7	-	ns
Rise time	$t_r$		-	3	-	
Turn-off delay time	$t_{D(OFF)}$		-	30	-	
Fall time	$t_f$		-	12	-	
Total gate charge	$Q_g$	$V_{DS}=-15\text{V}, I_D=-4\text{A}$ $V_{GS}=-4.5\text{V}$	-	8.5	-	nC
Gate-source charge	$Q_{gs}$		-	1.8	-	
Gate-drain charge	$Q_{gd}$		-	2.7	-	

### DRAIN-SOURCE DIODE CHARACTERISTICS

Diode forward voltage	$V_{SD}$	$V_{GS}=0V, I_S=-4A$	-	-0.81	-1.2	V
-----------------------	----------	----------------------	---	-------	------	---

### Typical Performance Characteristics

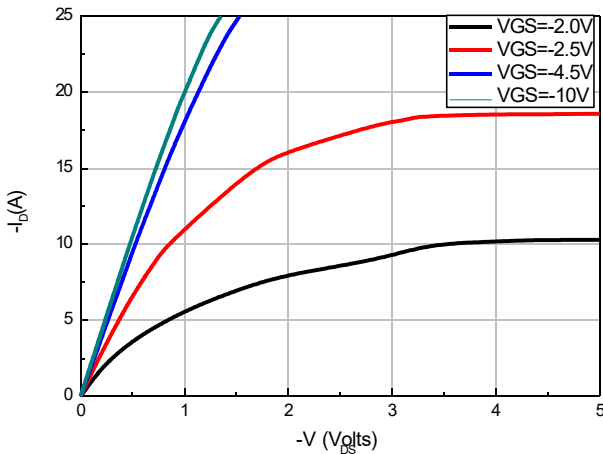

Fig 1: On-Region Characteristics

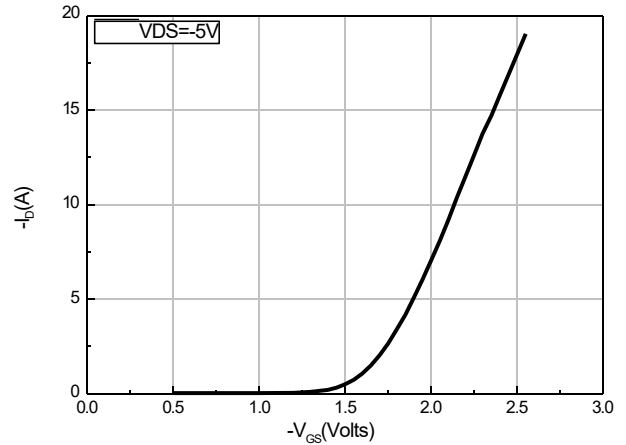

Figure 2: Transfer Characteristics

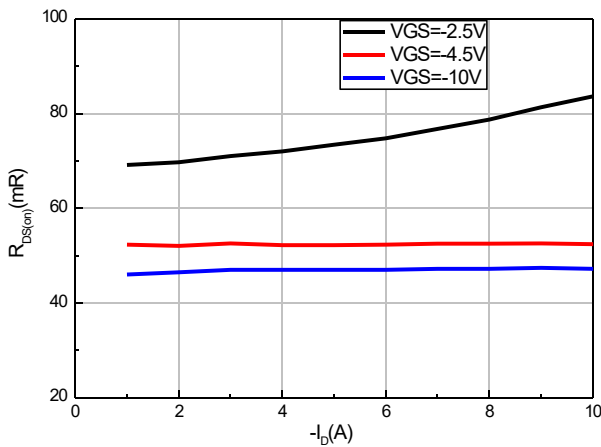

Figure 3: On-Resistance vs. Drain Current and Gate Voltage

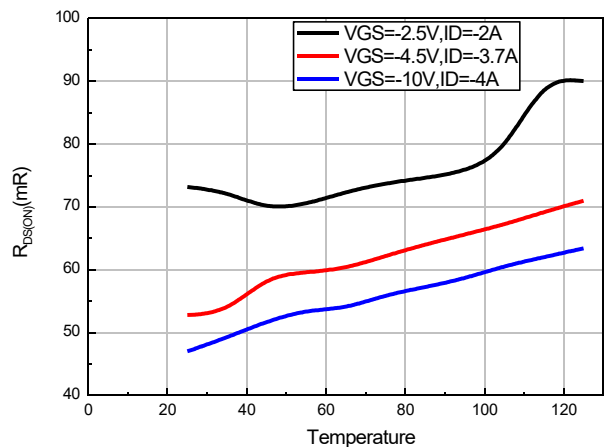

Figure 4: On-Resistance vs. Junction Temperature

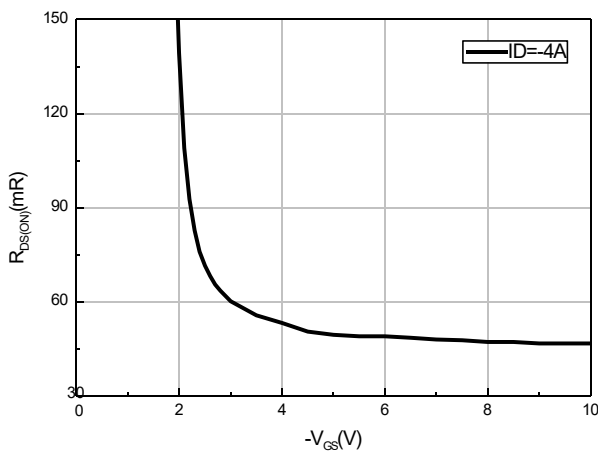

Figure 5: On-Resistance vs. Gate-Source Voltage

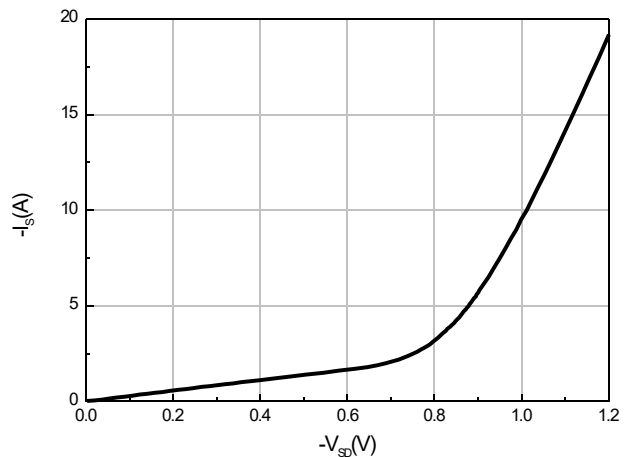
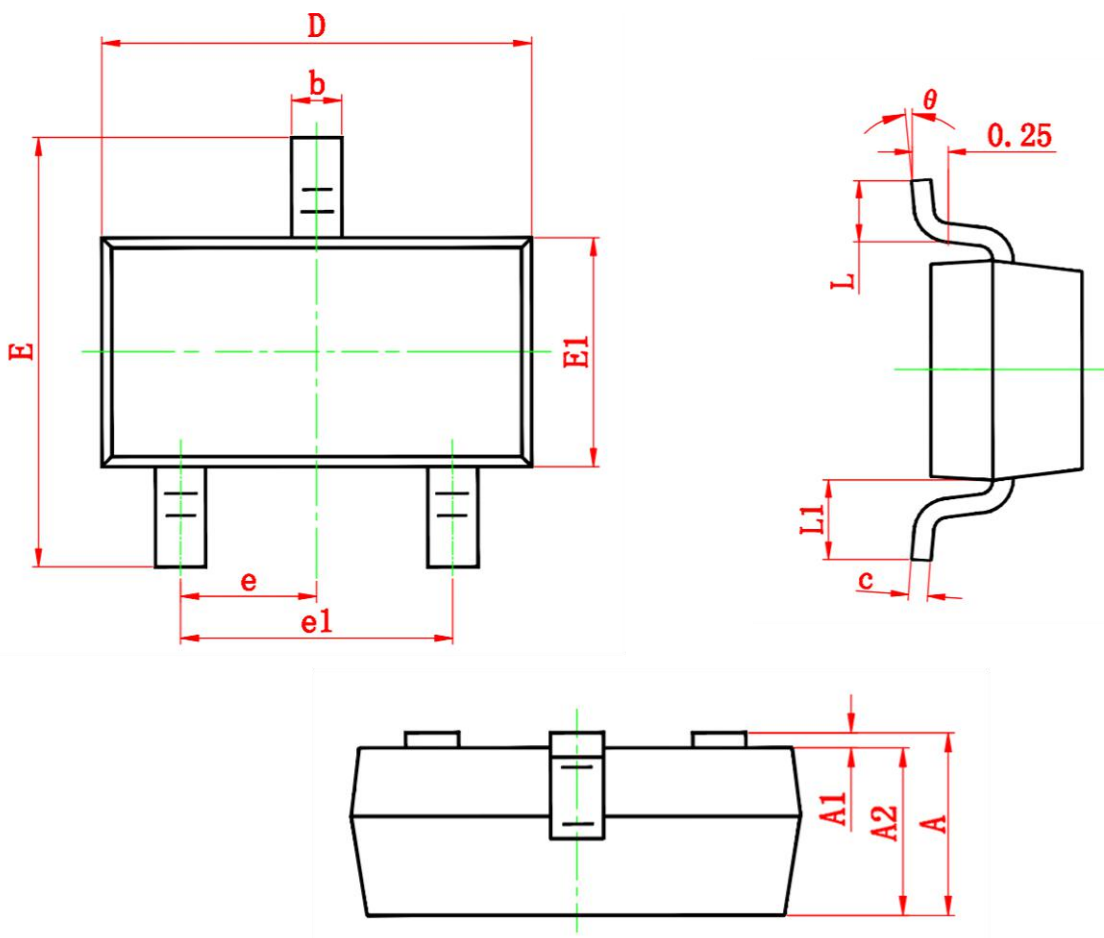

Figure 6: Body-Diode Characteristics

### Package Information

- SOT-23



Symbol	Dimensions In Millimeters		Dimensions In Inches	
	Min.	Max.	Min.	Max.
A	0.900	1.150	0.035	0.045
A1	0.000	0.100	0.000	0.004
A2	0.900	1.050	0.035	0.041
b	0.300	0.500	0.012	0.020
c	0.080	0.150	0.003	0.006
D	2.800	3.000	0.110	0.118
E	2.250	2.550	0.089	0.100
E1	1.200	1.400	0.047	0.055
e	0.950 TYP.		0.037 TYP.	
e1	1.800	2.000	0.071	0.079
L	0.300	0.500	0.012	0.020
L1	0.550 REF.		0.022 REF.	
$\theta$	0°	8°	0°	8°