

30V Dual N-Channel Enhancement Mode MOSFET

Description

The PECN4834 uses advanced trench technology to provide excellent $R_{DS(ON)}$ with low gate charge.

This device is suitable for high side switch in SMPS and general purpose applications.

General Features

- ◆ $V_{DS} = 30V, I_D = 20A$
 $R_{DS(ON)} = 10m\Omega$ (typical) @ $V_{GS} = 10V$
 $R_{DS(ON)} = 13.5m\Omega$ (typical) @ $V_{GS} = 4.5V$
- ◆ Excellent gate charge x $R_{DS(ON)}$ product(FOM)
- ◆ Very low on-resistance $R_{DS(ON)}$
- ◆ 150 °C operating temperature
- ◆ Pb-free lead plating
- ◆ 100% UIS tested

Application

- ◆ DC/DC Converter
- ◆ Ideal for high-frequency switching and synchronous rectification

Package

- ◆ PDFN5*6-8L-B *100% UIS TESTED!*
100% ΔV_{ds} TESTED!

Schematic diagram

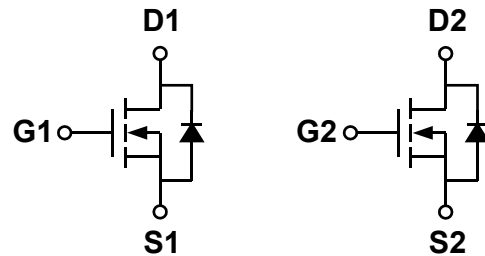

Marking and pin assignment

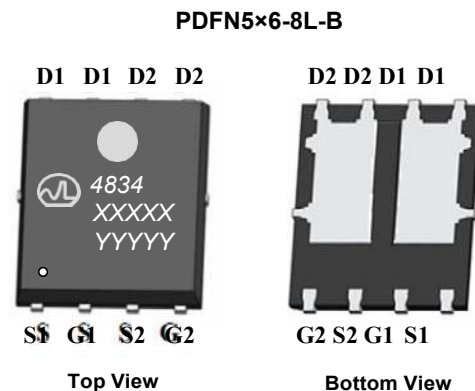

Note:

XXXX is the date code ,
 YYYY is the wafer lot number.

Ordering Information

Part Number	Storage Temperature	Package	Devices Per Reel
PECN4834D6-G	-55°C to +150°C	PDFN5*6-8L-B	5000

Absolute Maximum Ratings (TA=25°C unless otherwise noted)

parameter	symbol	limit	unit
Drain-source voltage	V_{DS}	30	V
Gate-source voltage	V_{GS}	±20	V
Drain Current-Continuous (Silicon Limited)	I_D	$T_A = 25^\circ C$	20
		$T_A = 75^\circ C$	16
Pulsed Drain Current (Package Limited)	I_{DM}	80	A
Single pulse avalanche energy	E_{AS}	22	mJ
Maximum power dissipation	P_D	$T_A = 25^\circ C$	31
		$T_A = 75^\circ C$	16
Operating junction Temperature range	T_j	-55—150	°C

Electrical Characteristics (TA=25°C unless otherwise noted)

Parameter	Symbol	Condition	Min	Typ	Max	Unit
OFF Characteristics						
Drain-source breakdown voltage	BV_{DSS}	$V_{GS}=0V, I_D=250\mu A$	30	-	-	V
Zero gate voltage drain current	I_{DSS}	$V_{DS}=30V, V_{GS}=0V$	-	-	1	μA
Gate-body leakage	I_{GSS}	$V_{DS}=0V, V_{GS}=\pm 20V$	-	-	± 100	nA
ON Characteristics						
Gate threshold voltage	$V_{GS(th)}$	$V_{DS}=V_{GS}, I_D=250\mu A$	1.0	1.65	3.0	V
Drain-source on-state resistance	$R_{DS(on)}$	$V_{GS}=10V, I_D=20A$	-	10	14	m Ω
		$V_{GS}=4.5V, I_D=10A$	-	13.5	17	
Forward transconductance	gfs	$V_{DS}=5V, I_D=10A$	-	43	-	S
Dynamic Characteristics						
IPECNut capacitance	C_{ISS}	$V_{DS}=15V, V_{GS}=0V$ $f=1.0MHz$	-	760	910	pF
Output capacitance	C_{OSS}		-	125	160	
Reverse transfer capacitance	C_{RSS}		-	70	100	
Gate resistance	R_g	$V_{GS}=0V, V_{DS}=0V,$ $f=1.0MHz$	-	1.6	2.4	Ω
Switching Characteristics						
Turn-on delay time	$t_{D(ON)}$	$V_{DS}=15V$ $V_{GS}=10V$ $R_L=1.5\Omega$ $R_{GEN}=3\Omega$	-	4.4	-	ns
Rise time	tr		-	9	-	
Turn-off delay time	$t_{D(OFF)}$		-	17	-	
Fall time	tf		-	6	-	
Total gate charge	Qg	$V_{DS}=15V, I_D=10A$ $V_{GS}=10V$	-	14	-	nC
Gate-source charge	Qgs		-	2.4	-	
Gate-drain charge	Qgd		-	3	-	

Thermal Characteristics

Thermal Resistance junction-to ambient	$R_{\theta JA}$	4	$^{\circ}C/W$
--	-----------------	---	---------------

Test Circuit:

① 、 EAS Test Circuit

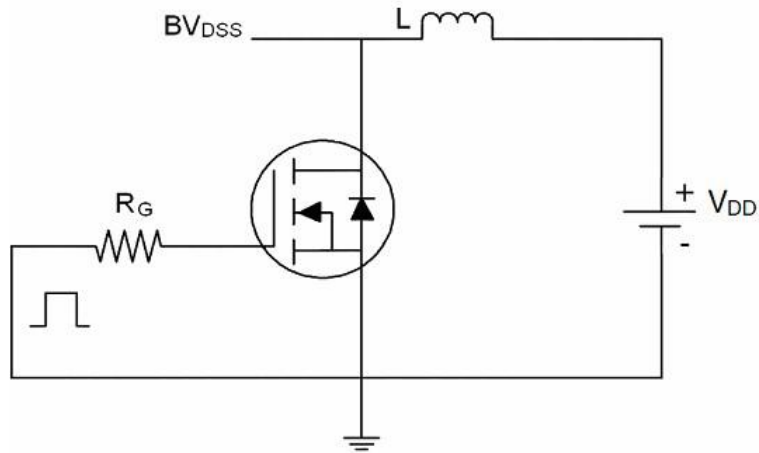

② 、 Gate Charge Test Circuit

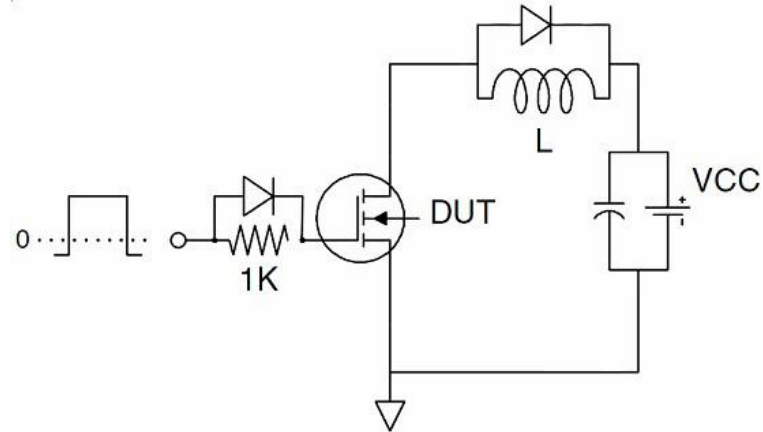

③ 、 Switch Time Test Circuit

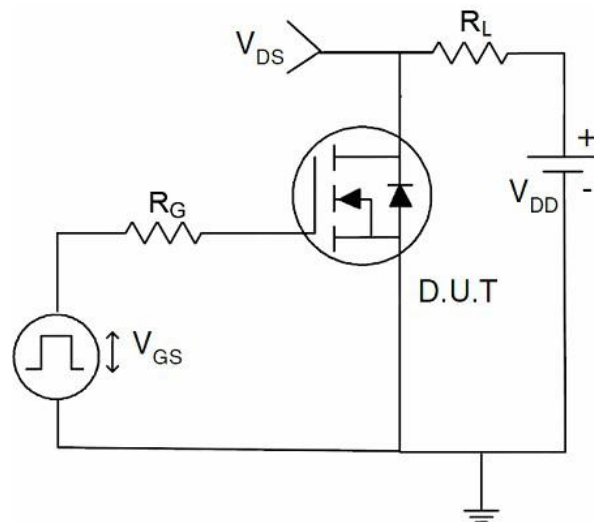

Package Information

- PDFN5*6-8L-B

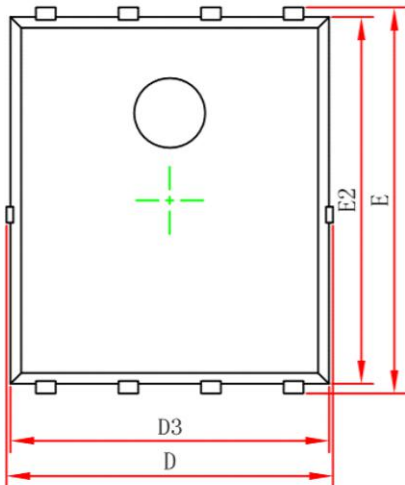

Top View

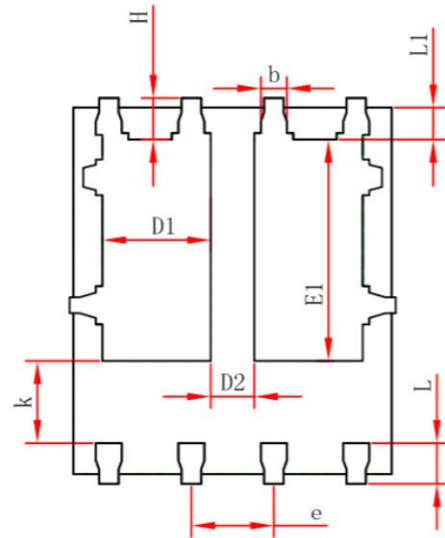

Bottom View

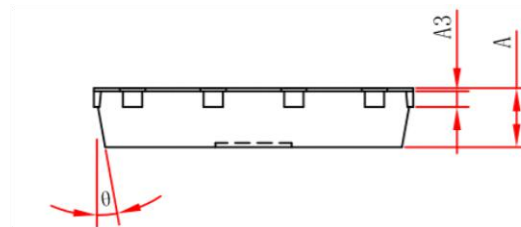

Side View

Symbol	Dimensions In Millimeters		Dimensions In Inches	
	Min.	Max.	Min.	Max.
A	0.900	1.000	0.035	0.039
A3	0.154REF.		0.006REF.	
D	4.944	5.096	0.195	0.201
E	5.974	6.126	0.235	0.241
D1	1.470	1.870	0.058	0.074
D2	0.470	0.870	0.019	0.034
E1	3.375	3.575	0.133	0.141
D3	4.824	4.976	0.190	0.196
E2	5.674	5.826	0.223	0.229
k	1.190	1.390	0.047	0.055
b	0.350	0.450	0.014	0.018
e	1.270TYP.		0.050TYP.	
L	0.559	0.711	0.022	0.028
L1	0.424	0.576	0.017	0.023
H	0.574	0.726	0.023	0.029
θ	10°	12°	10°	12°