

40V Dual N-Channel Enhancement Mode MOSFET

Description

The PECN4890SR uses advanced trench technology to provide excellent $R_{DS(ON)}$ with low gate charge.

This device is suitable for high side switch in SMPS and general purpose applications.

General Features

- ◆ $V_{DS} = 40V, I_D = 12A$
 $R_{DS(ON)} = 7.8m\Omega$ (typical) @ $V_{GS} = 10V$
 $R_{DS(ON)} = 9.6m\Omega$ (typical) @ $V_{GS} = 4.5V$
- ◆ Excellent gate charge x $R_{DS(ON)}$ product(FOM)
- ◆ Very low on-resistance $R_{DS(ON)}$
- ◆ 150 °C operating temperature
- ◆ Pb-free lead plating
- ◆ 100% UIS tested

Application

- ◆ DC/DC Converter
- ◆ Ideal for high-frequency switching and synchronous rectification

Package

- ◆ SOP-8

100% UIS TESTED!
100% ΔV_{ds} TESTED!

Schematic diagram

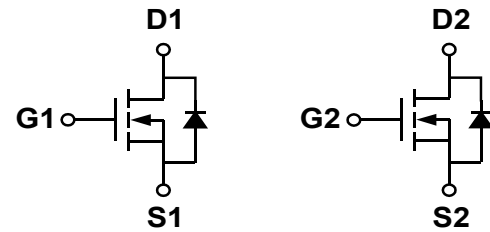

Marking and pin assignment

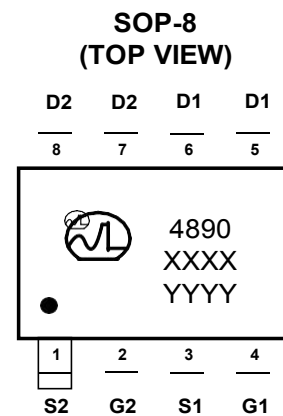

Note:

XXXX is the date code ,
 YYYY is the Quality Code.



Ordering Information

Part Number	Storage Temperature	Package	Devices Per Reel
PECN4890SR-G	-55°C to +150°C	SOP-8	4000

Absolute Maximum Ratings (TA=25°C unless otherwise noted)

parameter	symbol	limit	unit
Drain-source voltage	V_{DS}	40	V
Gate-source voltage	V_{GS}	±20	V
Drain Current-Continuous (Silicon Limited)	$T_A = 25^\circ C$	12	A
	$T_A = 75^\circ C$	8	
Pulsed Drain Current (Package Limited)	I_{DM}	48	A
Single pulse avalanche energy	E_{AS}	30	mJ
Maximum power dissipation	$T_A = 25^\circ C$	3	W
	$T_A = 75^\circ C$	2.1	
Operating junction Temperature range	T_j	-55—150	°C

Electrical Characteristics (TA=25°C unless otherwise noted)

Parameter	Symbol	Condition	Min	Typ	Max	Unit
Static Characteristics						
Drain-source breakdown voltage	BV_{DSS}	$V_{GS}=0V, I_D=250\mu A$	40	-	-	V
Zero gate voltage drain current	I_{DSS}	$V_{DS}=40V, V_{GS}=0V$ $T_J=85^\circ C$	-	-	1	μA
			-	-	5	
Gate Leakage Current	I_{GSS}	$V_{DS}=0V, V_{GS}=\pm 20V$	-	-	± 100	nA
Gate threshold voltage	$V_{GS(th)}$	$V_{DS}=V_{GS}, I_D=250\mu A$	1	1.5	2.3	V
Drain-source on-state resistance ¹	$R_{DS(ON)}$	$V_{GS}=10V, I_D=12A$	-	7.8	9	m Ω
		$V_{GS}=4.5V, I_D=8A$		9.6	12	
Forward Transconductance	g_{FS}	$V_{DS} = 5V, I_D = 12A$		60		S
Diode Characteristics						
Diode Forward Voltage	V_{SD}	$I_{SD}=1A, V_{GS}=0V$	-	0.82	1.1	V
Diode Continuous Forward Current	I_S		-	-	2.5	A
Reverse Recovery Time	t_{rr}	$I_F=12A,$ $di/dt=100A/\mu s$	-	30	-	ns
Reverse Recovery Charge	Q_{rr}		-	19	-	nC
Dynamic Characteristics						
Gate Resistance	R_G	$V_{GS}=0V, V_{DS}=0V, f=1MHz$	-	3.5	-	Ω
IPECNut capacitance	C_{ISS}	$V_{GS}=0V, V_{DS}=20V$ $f=1.0MHz$	-	1500	-	pF
Output capacitance	C_{OSS}		-	215	-	
Reverse transfer capacitance	C_{RSS}		-	135	-	
Turn-on delay time	$t_{D(ON)}$	$V_{GS}=10V, V_{DS}=20V, R_L=2\Omega,$ $R_G=3\Omega$	-	6.4	-	ns
Turn-on Rise time	t_r		-	17.2	-	
Turn-off delay time	$t_{D(OFF)}$		-	29.6	-	
Turn-off Fall time	t_f		-	16.8	-	
Total gate charge	Q_g	$V_{GS}=10V, V_{DS}=20V, I_D=12A$	-	27.2	-	nC
Gate-source charge	Q_{gs}		-	4.5	-	
Gate-drain charge	Q_{gd}		-	6.4	-	

Thermal Characteristics

Parameter	Symbol	Typ	Max	Unit
Maximum Junction-to-Ambient ^A	$\leq 10s$	33	40	$^\circ C/W$
Maximum Junction-to-Ambient ^A	Steady-State			
Maximum Junction-to-Lead ^B	Steady-State	16	24	

A: The value of $R_{\theta JA}$ is measured with the device mounted on 1 in² FR-4 board with 2oz. Copper, in a still air environment with $T_A=25^\circ C$. The value in any given application depends on the user's specific board design. The current rating is based on the $t \leq 10s$ thermal resistance rating.

B: The $R_{\theta JA}$ is the sum of the thermal impedance from junction to lead $R_{\theta JC}$ and lead to ambient.

Test Circuit:

① 、 EAS Test Circuit

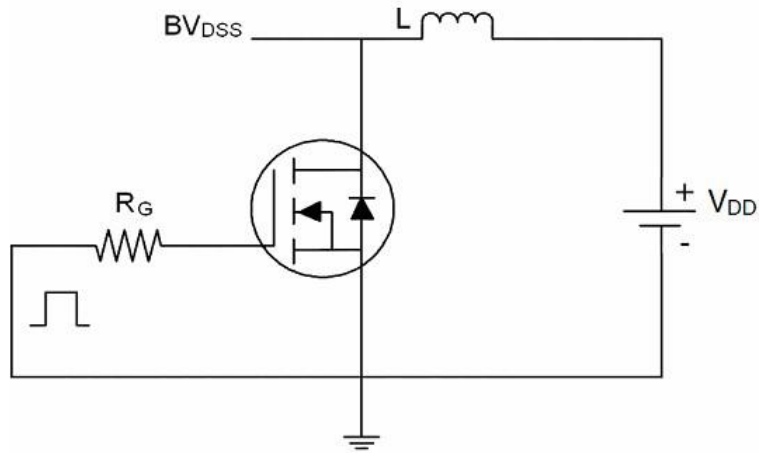

② 、 Gate Charge Test Circuit

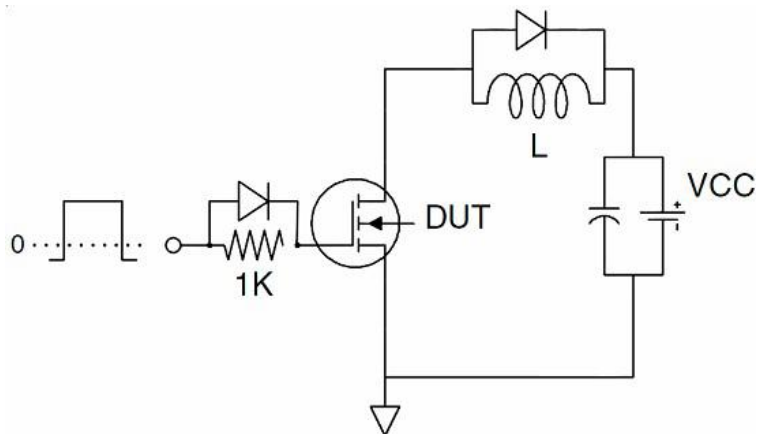

③ 、 Switch Time Test Circuit

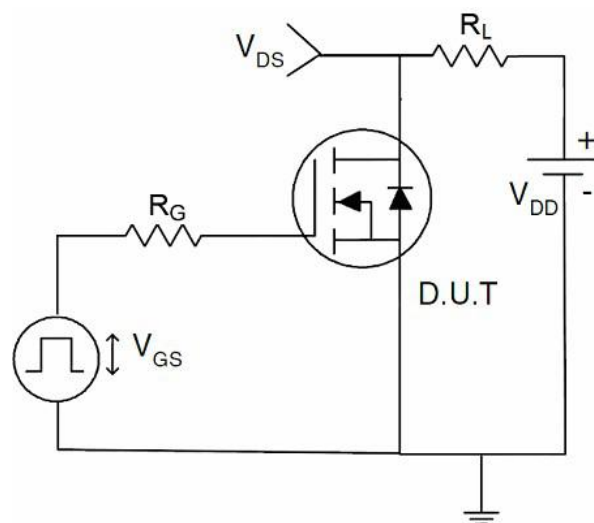

Package Information

- SOP-8

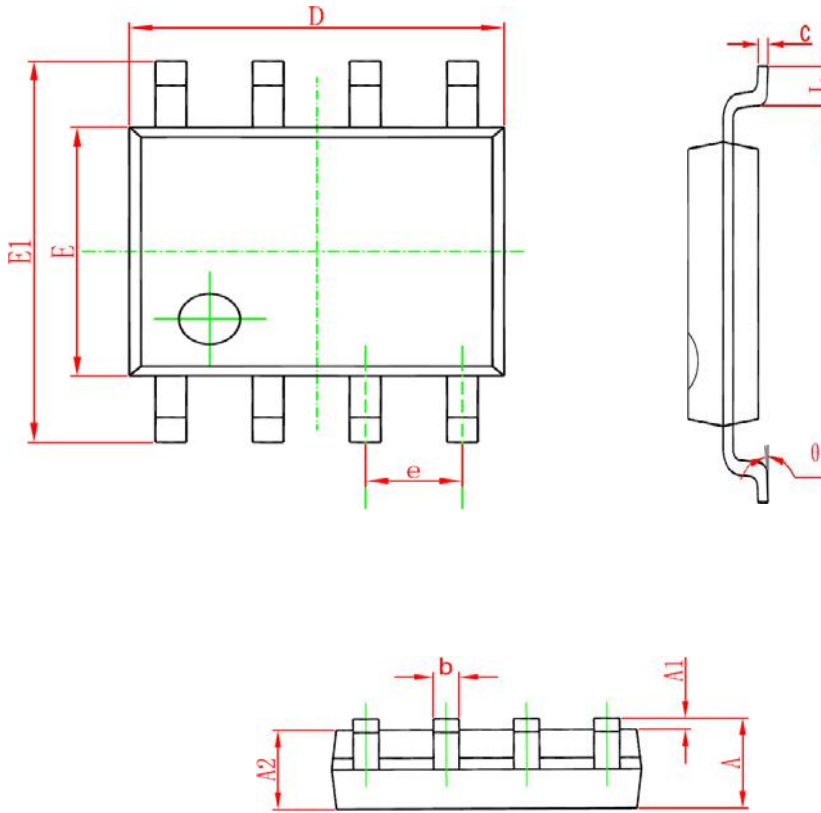

Symbol	Dimensions In Millimeters		Dimensions In Inches	
	Min	Max	Min	Max
A	1.350	1.750	0.053	0.069
A1	0.100	0.250	0.004	0.010
A2	1.350	1.550	0.053	0.061
b	0.330	0.510	0.013	0.020
c	0.170	0.250	0.006	0.010
D	4.700	5.100	0.185	0.200
E	3.800	4.000	0.150	0.157
E1	5.800	6.200	0.228	0.244
e	1.270 (BSC)		0.050 (BSC)	
L	0.400	1.270	0.016	0.050
θ	0°	8°	0°	8°

Recommended Minimum Pads

- SOP-8

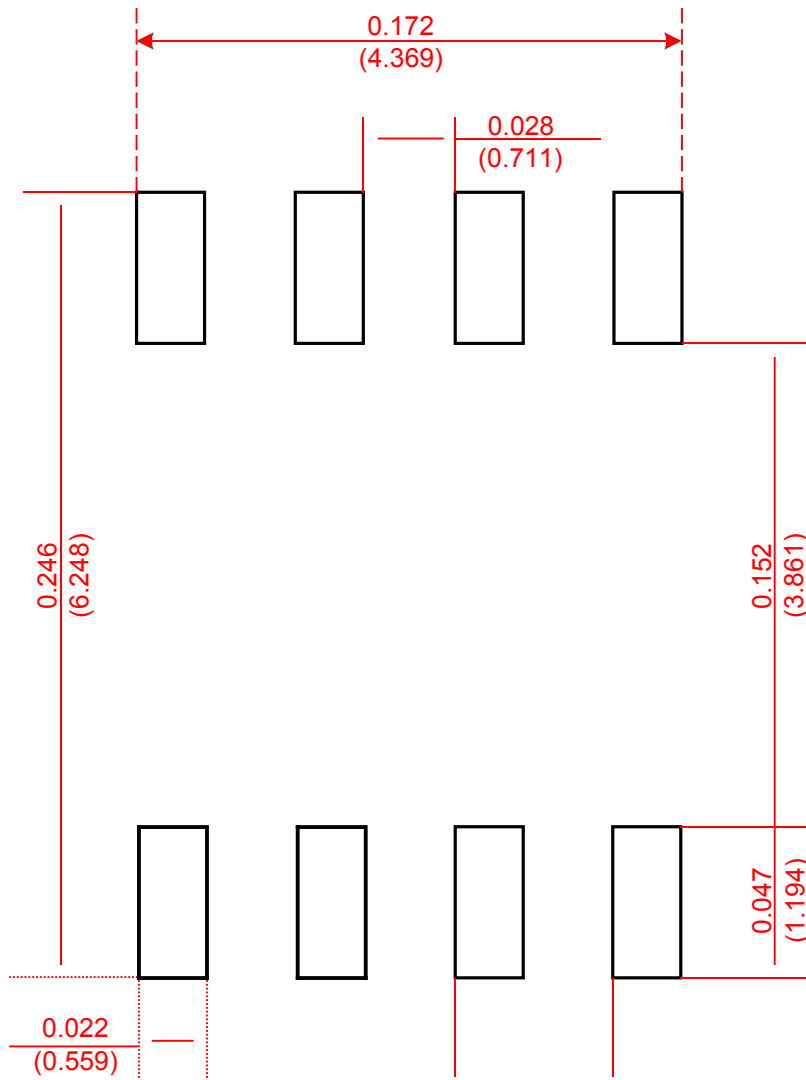

**Recommended Minimum Pads
Dimensions in Inches/(mm)**

Tape and Reel

- SOP-8

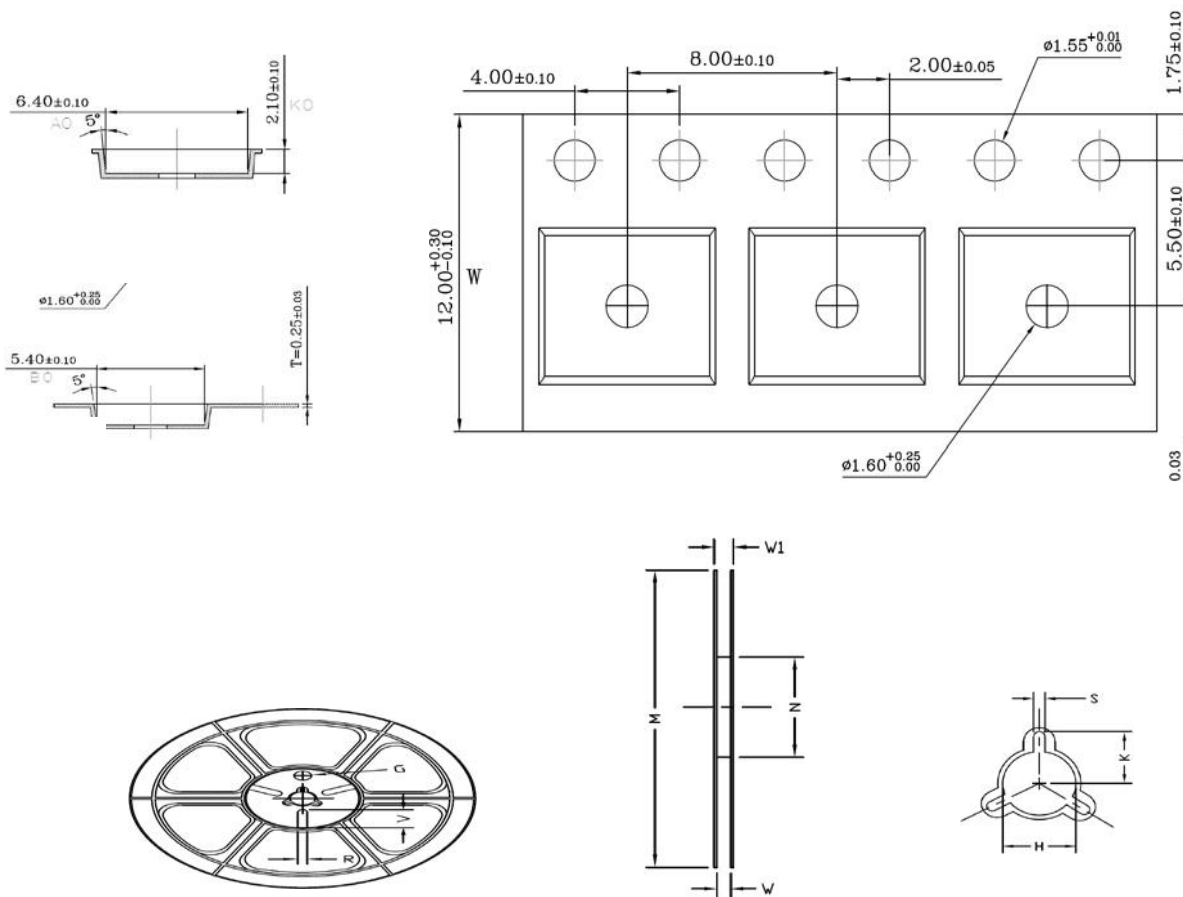

Tape Size	Reel Size	M	N	W	W1	H	K	S	G	R	V
12mm	$\phi 330$	$\phi 330.00$ ± 0.50	$\phi 97.00$ ± 0.30	13.00 ± 0.30	17.40 ± 1.00	$\phi 13.00$ ± 0.5	10.6	2.00 ± 0.50	—	—	—

