

100V N-Channel Enhancement Mode MOSFET

Description

The PECN4N10MR uses advanced trench technology to provide excellent $R_{DS(ON)}$, low gate charge and high density cell Design for ultra low on-resistance. This device is suitable for use as a load switch or in PWM applications.

General Features

- ◆ $V_{DS} = 100V$, $I_D = 4A$
 $R_{DS(ON)}(Typ.) = 130m\Omega$ @ $V_{GS} = 10V$
 $R_{DS(ON)}(Typ.) = 140m\Omega$ @ $V_{GS} = 4.5V$
- ◆ High power and current handing capability
- ◆ Lead free product is acquired
- ◆ Surface mount package

Application

- ◆ PWM applications
- ◆ Load switch

Package

- ◆ SOT-23-3L



Schematic diagram

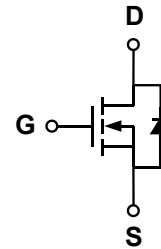

Marking and pin assignment

SOT-23-3L
(TOP VIEW)

D

3

4N10

1
G

2
S

Ordering Information

Part Number	Storage Temperature	Package	Devices Per Reel
PECN4N10MR-G	-55°C to +150°C	SOT-23-3L	3000

Absolute Maximum Ratings (TA=25°C unless otherwise noted)

parameter	symbol	limit	unit
Drain-source voltage	V_{DS}	100	V
Gate-source voltage	V_{GS}	±20	V
Continuous Drain Current	I_D	$T_A = 25^\circ C$	4
		$T_A = 70^\circ C$	3
Pulsed Drain Current ^C	I_{DM}	16	A
Maximum power dissipation ^B	P_D	$T_A = 25^\circ C$	1.4
		$T_A = 70^\circ C$	0.9
Operating junction Temperature range	T_j	-55—150	°C

Thermal Characteristics

Parameter		Symbol	Typ	Max	Unit
Maximum Junction-to-Ambient ^A	≤ 10s	R _{θJA}	70	90	°C/W
Maximum Junction-to-Ambient ^{A D}	Steady-State		100	125	
Maximum Junction-to-Lead ^B	Steady-State	R _{θJL}	63	80	

A. The value of R_{θJA} is measured with the device mounted on 1in2 FR-4 board with 2oz. Copper, in a still air environment with T_A = 25°C. The value in any given application depends on the user's specific board design.

B. The power dissipation P_D is based on T_{J(MAX)} = 150°C, using ≤ 10s junction-to-ambient thermal resistance.

C. Repetitive rating, pulse width limited by junction temperature T_{J(MAX)} = 150°C. Ratings are based on low frequency and duty cycles to keep initial T_J = 25°C.

D. The R_{θJA} is the sum of the thermal impedance from junction to lead R_{θJL} and lead to ambient.

Electrical Characteristics (TA=25°C unless otherwise noted)

Parameter	Symbol	Condition	Min	Typ	Max	Unit
OFF Characteristics						
Drain-source breakdown voltage	BV _{DSS}	V _{GS} =0V, I _D =250μA	100	-	-	V
Zero gate voltage drain current	I _{DSS}	V _{DS} =100V, V _{GS} =0V	-	-	1	μA
Gate-body leakage	I _{GSS}	V _{DS} =0V, V _{GS} =±20V	-	-	±100	nA
ON Characteristics						
Gate threshold voltage	V _{GS(th)}	V _{DS} =V _{GS} , I _D =250μA	1.2	1.9	2.5	V
Drain-source on-state resistance	R _{DS(ON)}	V _{GS} =10V, I _D =4A	-	130	170	mΩ
		V _{GS} =4.5V, I _D =3A	-	140	180	
Forward transconductance	g _{fs}	V _{DS} =5V, I _D =4A	-	5	-	S
Dynamic Characteristics						
Input capacitance	C _{ISS}	V _{DS} =50V, V _{GS} =0V f=1.0MHz	-	650	-	pF
Output capacitance	C _{OSS}		-	24	-	
Reverse transfer capacitance	C _{RSS}		-	20	-	
Switching Characteristics						
Turn-on delay time	t _{D(ON)}	V _{DD} =50V R _L =19 ohm V _{GS} =10V R _G =3ohm	-	6	-	ns
Rise time	tr		-	4	-	
Turn-off delay time	t _{D(OFF)}		-	20	-	
Fall time	tf		-	4	-	
Total gate charge	Qg	V _{DS} =50V I _D =1A V _{GS} =10V	-	20	-	nC
Gate-source charge	Qgs		-	2.1	-	
Gate-drain charge	Qgd		-	3	-	
DRAIN-SOURCE DIODE CHARACTERISTICS						
Diode forward voltage	V _{SD}	V _{GS} =0V, I _S =2A	-	0.76	1.16	V

Package Information

- SOT-23-3L

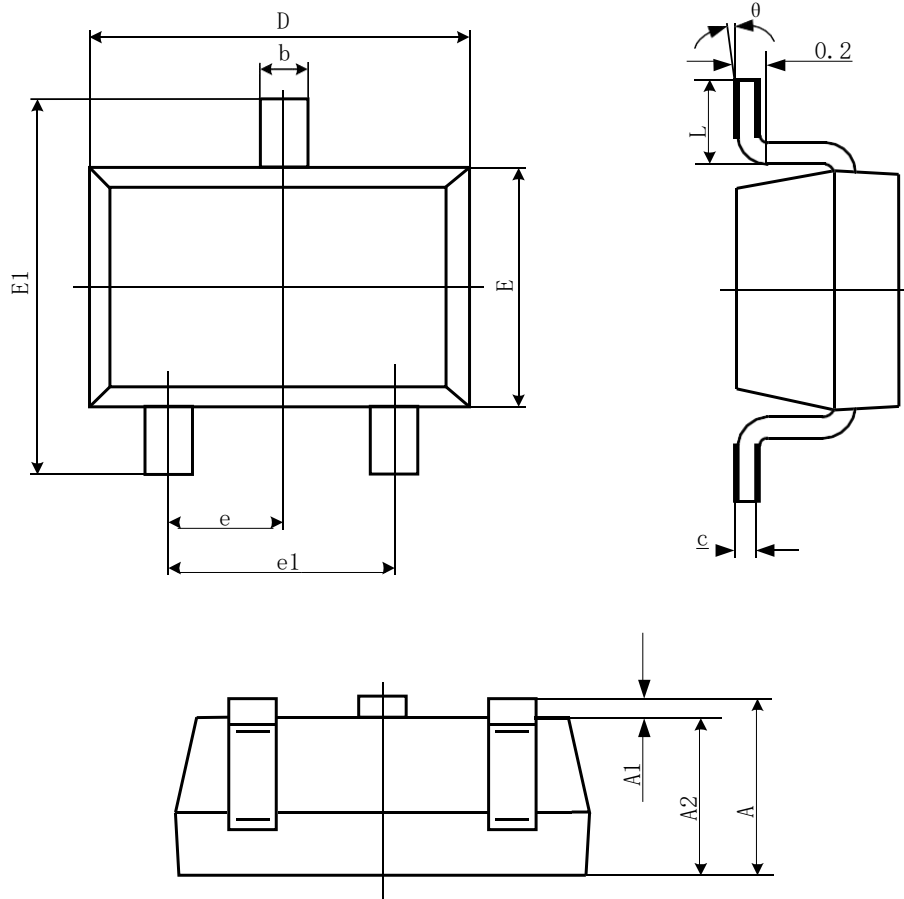

Symbol	Dimensions In Millimeters		Dimensions In Inches	
	Min	Max	Min	Max
A	1.050	1.250	0.041	0.049
A1	0.000	0.100	0.000	0.004
A2	1.050	1.150	0.041	0.045
b	0.300	0.500	0.012	0.020
c	0.100	0.200	0.004	0.008
D	2.820	3.020	0.111	0.119
E	1.500	1.700	0.059	0.067
E1	2.650	2.950	0.104	0.116
e	0.950(BSC)		0.037(BSC)	
e1	1.800	2.000	0.071	0.079
L	0.300	0.600	0.012	0.024
θ	0°	8°	0°	8°