

## 60V N-Channel Enhancement Mode MOSFET

### Description

The PECN6030D6 uses advanced trench technology that is uniquely optimized to provide the most efficient high frequency switching performance. Both conduction and switching power losses are minimized due to an extremely low combination of  $R_{DS(on)}$  and  $Q_g$ . This device is ideal for high-frequency switching and synchronous rectification.

### General Features

- ◆  $V_{DS} = 60V$   $I_D = 30A$   
 $R_{DS(on)}(Typ.) = 10m\Omega$  @  $V_{GS} = 10V$   
 $R_{DS(on)}(Typ.) = 12m\Omega$  @  $V_{GS} = 4.5V$
- ◆ Excellent gate charge x  $R_{DS(on)}$  product(FOM)
- ◆ Very low on-resistance  $R_{DS(on)}$
- ◆ 150 °C operating temperature
- ◆ 100% UIS tested

### Application

- ◆ Synchronous Rectification in DC/DC and AC/DC Converters
- ◆ Industrial and Motor Drive applications

*100% UIS TESTED!*

*100%  $\Delta V_{ds}$  TESTED!*

### Schematic diagram

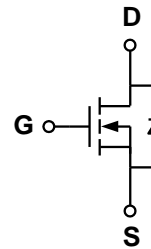

### Marking and pin assignment

PDFN5\*6-8L-A

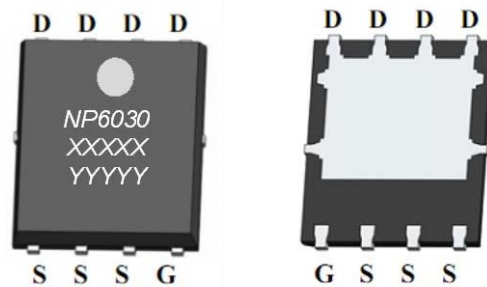

Top View

Bottom View

XXXXX—Date Code

YYYYY—Quality Code.



### Ordering Information

Part Number	Storage Temperature	Package	Devices Per Reel
PECN6030D6-G	-55°C to +150°C	PDFN5*6-8L-A	5000

### Absolute Maximum Ratings (TA=25°C unless otherwise noted)

parameter	symbol	limit	unit
Drain-source voltage	$V_{DS}$	60	V
Gate-source voltage	$V_{GS}$	±20	V
Continuous Drain Current	$I_D$	TC=25°C	30
		TC=70°C	24
Pulsed Drain Current	$I_{DP}$	120	A
Avalanche energy ( $T_j=25^\circ C$ , $V_{DD}=30V$ , $V_G=10V$ , $L=0.5mH$ , $R_g=25\Omega$ )	$E_{AS}$	200	mJ
Power Dissipation	$P_D$	TC=25°C	3
		TC=70°C	2.1
Operating junction Temperature range	$T_j$	-55—150	°C

## Electrical Characteristics (TA=25°C unless otherwise noted)

Parameter	Symbol	Condition	Min	Typ	Max	Unit
<b>Static Characteristics</b>						
Drain-source breakdown voltage	$BV_{DSS}$	$V_{GS}=0V, I_D=250\mu A$	60	-	-	V
Zero gate voltage drain current	$I_{DSS}$	$V_{DS}=60V, V_{GS}=0V$ $T_J=85^\circ C$	-	-	1	$\mu A$
			-	-	5	
Gate Leakage Current	$I_{GSS}$	$V_{DS}=0V, V_{GS}=\pm 20V$	-	-	$\pm 100$	nA
Gate threshold voltage	$V_{GS(th)}$	$V_{DS}=V_{GS}, I_D=250\mu A$	1.0	1.5	2.0	V
Drain-source on-state resistance	$R_{DS(ON)}$	$V_{GS}=10V, I_D=30A$	-	10	13	m $\Omega$
		$V_{GS}=4.5V, I_D=25A$		12	15	
Forward Transconductance	$g_{FS}$	$V_{DS}=10V, I_D=30A$	35	-	-	S
<b>Diode Characteristics</b>						
Diode Forward Voltage	$V_{SD}$	$I_{SD}=30A, V_{GS}=0V$	-	0.82	1.2	V
Diode Continuous Forward Current	$I_S$		-	-	30	A
Reverse Recovery Time	$t_{rr}$	$T_J = 25^\circ C, I_F = I_S, di/dt = 100A/\mu s$	-	40	-	ns
Reverse Recovery Charge	$Q_{rr}$		-	50	-	nC
<b>Dynamic Characteristics</b>						
Gate Resistance	$R_G$	$V_{GS}=0V, V_{DS}=0V, f=1MHz$	-	1.2	1.8	$\Omega$
Input capacitance	$C_{ISS}$	$V_{GS}=0V, V_{DS}=30V$ $f=1.0MHz$	-	755	-	pF
Output capacitance	$C_{OSS}$		-	220	-	
Reverse transfer capacitance	$C_{RSS}$		-	20	-	
Turn-on delay time	$t_{D(ON)}$	$V_{GS}=10V, V_{DS}=30V, R_L=1.5\Omega,$ $R_G=3\Omega$	-	5	-	ns
Turn-on Rise time	$t_r$		-	3	-	
Turn-off delay time	$t_{D(OFF)}$		-	20	-	
Turn-off Fall time	$t_f$		-	3	-	
Total gate charge	$Q_g$	$V_{GS}=10V, V_{DS}=30V, I_D=30A$	-	13.5	-	nC
Gate-source charge	$Q_{gs}$		-	2.5	-	
Gate-drain charge	$Q_{gd}$		3	3.0	-	

## Thermal Characteristics

Parameter	Symbol	Typ	Max	Unit
Maximum Junction-to-Ambient <sup>A</sup>	$R_{\theta JA}$	33	40	$^\circ C/W$
Maximum Junction-to-Ambient <sup>A</sup>		Steady-State	59	
Maximum Junction-to-Lead <sup>B</sup>	$R_{\theta JC}$	16	24	

A: The value of  $R_{\theta JA}$  is measured with the device mounted on 1in 2 FR-4 board with 2oz. Copper, in a still air environment with  $T_A=25^\circ C$ . The value in any given application depends on the user's specific board design. The current rating is based on the  $t \leq 10s$  thermal resistance rating.

B: The  $R_{\theta JA}$  is the sum of the thermal impedance from junction to lead  $R_{\theta JL}$  and lead to ambient.

## Package Information

- PDFN5\*6-8L-A

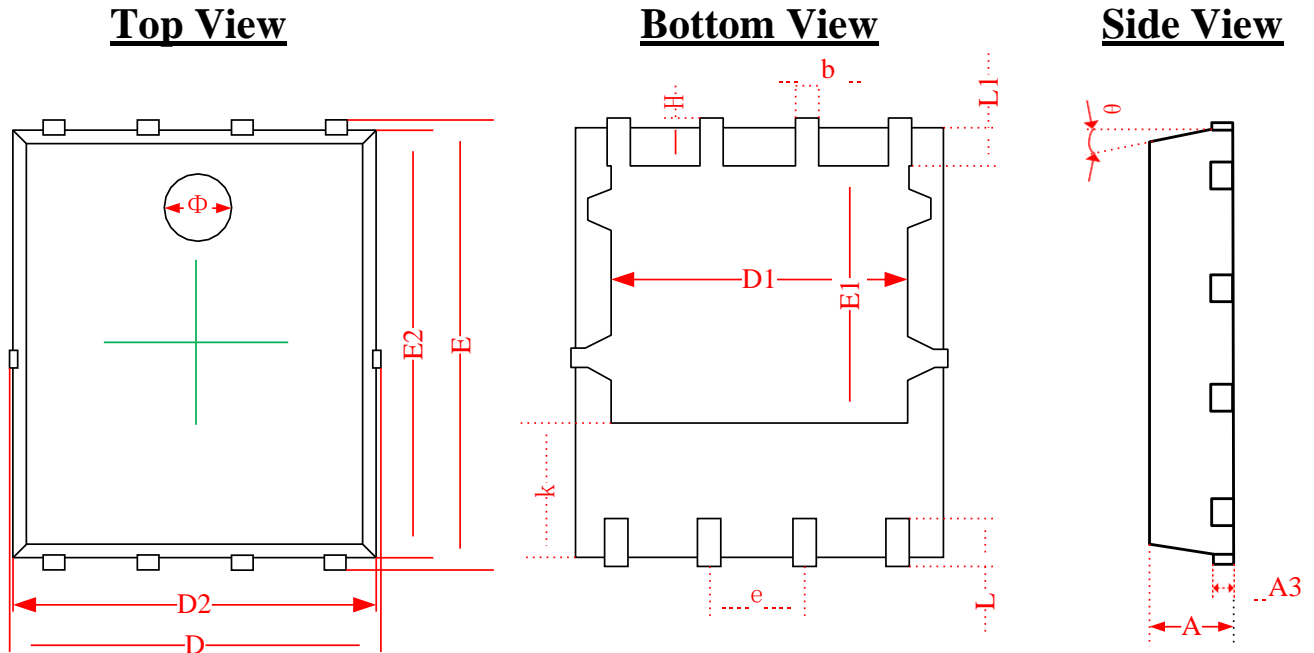

SYMBOLS	DIMENSIONS IN MILLIMETERS			DIMENSIONS IN INCHES		
	MIN	NOM	MAX	MIN	NOM	MAX
A	0.870	0.900	0.930	0.034	0.035	0.036
A3	0.152REF.			0.006REF.		
D	4.944	5.020	5.096	0.195	0.198	0.201
E	5.974	6.050	6.126	0.235	0.238	0.241
D1	3.910	4.010	4.110	0.154	0.158	0.162
E1	3.375	3.475	3.575	0.133	0.137	0.141
D2	4.870	4.900	4.930	0.192	0.193	0.194
E2	5.720	5.750	5.780	0.226	0.227	0.228
k	1.190	1.290	1.390	0.047	0.051	0.055
b	0.350	0.380	0.410	0.014	0.015	0.016
e	1.270TYP.			0.050TYP.		
L	0.559	0.635	0.711	0.022	0.025	0.028
L1	0.424	0.500	0.576	0.017	0.020	0.023
H	0.574	0.650	0.726	0.023	0.026	0.029
$\theta$	10°	11°	12°	10°	11°	12°
$\Phi$	1.150	1.200	1.250	0.045	0.047	0.049