

60V N-Channel Enhancement Mode MOSFET

Description

The PECN6080D6 uses Shield Gate Trench technology that is uniquely optimized to provide the most efficient high frequency switching performance. Both conduction and switching power losses are minimized due to an extremely low combination of $R_{DS(on)}$ and Q_g . This device is ideal for high-frequency switching and synchronous rectification.

General Features

- ◆ $V_{DS} = 60V$ $I_D = 80A$
 $R_{DS(on)}(Typ.) = 3.6m\Omega @ V_{GS} = 10V$
 $R_{DS(on)}(Typ.) = 5m\Omega @ V_{GS} = 4.5V$
- ◆ Excellent gate charge x $R_{DS(on)}$ product(FOM)
- ◆ Very low on-resistance $R_{DS(on)}$
- ◆ 150 °C operating temperature
- ◆ 100% UIS tested

Application

- ◆ Synchronous Rectification in DC/DC and AC/DC Converters
- ◆ Industrial and Motor Drive applications

100% UIS TESTED!
100% ΔV_{ds} TESTED!

Schematic diagram

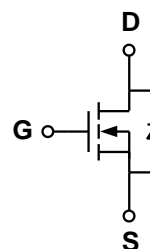

Marking and pin assignment

PDFN5*6-8L-A

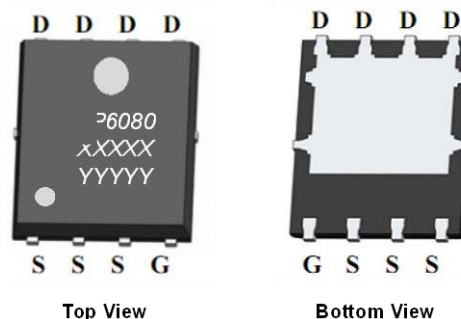

XXXXX—Wafer Lot No. YYYYY—
 Quality Code



Ordering Information

Part Number	Storage Temperature	Package	Devices Per Reel
PECN6080D6-G	-55°C to +150°C	PDFN5*6-8L-A	5000

Absolute Maximum Ratings (TA=25°C unless otherwise noted)

parameter	symbol	limit	unit
Drain-source voltage	V_{DS}	60	V
Gate-source voltage	V_{GS}	± 20	V
Continuous Drain Current	I_D	TC=25°C	80
		TC=70°C	60
Pulsed Drain Current	I_{DP}	320	A
Avalanche energy ($T_j = 25^\circ C, V_{DD} = 30V, V_G = 10V, L = 0.5mH, R_g = 25\Omega$)	E_{AS}	500	mJ
Power Dissipation	P_D	TC=25°C	37.5
		TC=70°C	15
Operating junction Temperature range	T_j	-55—150	°C

Electrical Characteristics (TA=25°C unless otherwise noted)

Parameter	Symbol	Condition	Min	Typ	Max	Unit
Static Characteristics						
Drain-source breakdown voltage	BV_{DSS}	$V_{GS}=0V, I_D=250\mu A$	60	-	-	V
Zero gate voltage drain current	I_{DSS}	$V_{DS}=60V, V_{GS}=0V$	-	-	1	μA
		$T_J=85^\circ C$	-	-	5	
Gate Leakage Current	I_{GSS}	$V_{DS}=0V, V_{GS}=\pm 20V$	-	-	± 100	nA
Gate threshold voltage	$V_{GS(th)}$	$V_{DS}=V_{GS}, I_D=250\mu A$	1.0	1.5	2.0	V
Drain-source on-state resistance	$R_{DS(ON)}$	$V_{GS}=10V, I_D=8A$	-	3.6	4	m Ω
		$V_{GS}=4.5V, I_D=60A$	-	5	6.5	
Forward Transconductance	g_{FS}	$V_{DS}=10V, I_D=40A$	40	-	-	S
Diode Characteristics						
Diode Forward Voltage	V_{SD}	$I_{SD}=40A, V_{GS}=0V$	-	0.82	1.2	V
Diode Continuous Forward Current	I_S		-	-	80	A
Reverse Recovery Time	t_{rr}	$T_J = 25^\circ C, I_F = I_S \text{ di/dt} = 100A/\mu s$	-	47	-	ns
Reverse Recovery Charge	Q_{rr}		-	59	-	nC
Dynamic Characteristics						
Gate Resistance	R_G	$V_{GS}=0V, V_{DS}=0V, f=1MHz$	-	1.2	1.8	Ω
Input capacitance	C_{ISS}	$V_{GS}=0V, V_{DS}=30V$ $f=1.0MHz$	-	3400	-	pF
Output capacitance	C_{OSS}		-	650	-	
Reverse transfer capacitance	C_{RSS}		-	20	-	
Turn-on delay time	$t_{D(ON)}$	$V_{GS}=10V, V_{DS}=30V, R_L=1.5\Omega,$ $R_G=3\Omega$	-	11	-	ns
Turn-on Rise time	t_r		-	5	-	
Turn-off delay time	$t_{D(OFF)}$		-	56	-	
Turn-off Fall time	t_f		-	12	-	
Total gate charge	Q_g	$V_{GS}=10V, V_{DS}=30V, I_D=80A$	-	51	-	nC
Gate-source charge	Q_{gs}		-	12	-	
Gate-drain charge	Q_{gd}		-	7.3	-	

Thermal Characteristics

Parameter	Symbol	Typ	Max	Unit
Maximum Junction-to-Ambient ^A	$\leq 10s$	20	25	$^\circ C/W$
Maximum Junction-to-Ambient ^A	Steady-State			
Maximum Junction-to-Lead ^B	Steady-State	2.7	3.3	

A: The value of R_{qJA} is measured with the device mounted on 1 in 2 FR-4 board with 2oz. Copper, in a still air environment with $T_A=25^\circ C$. The value in any given application depends on the user's specific board design. The current rating is based on the $t \leq 10s$ thermal resistance rating.

B: The R_{qJA} is the sum of the thermal impedance from junction to lead R_{qJL} and lead to ambient.

Package Information

- PDFN5*6-8L-A

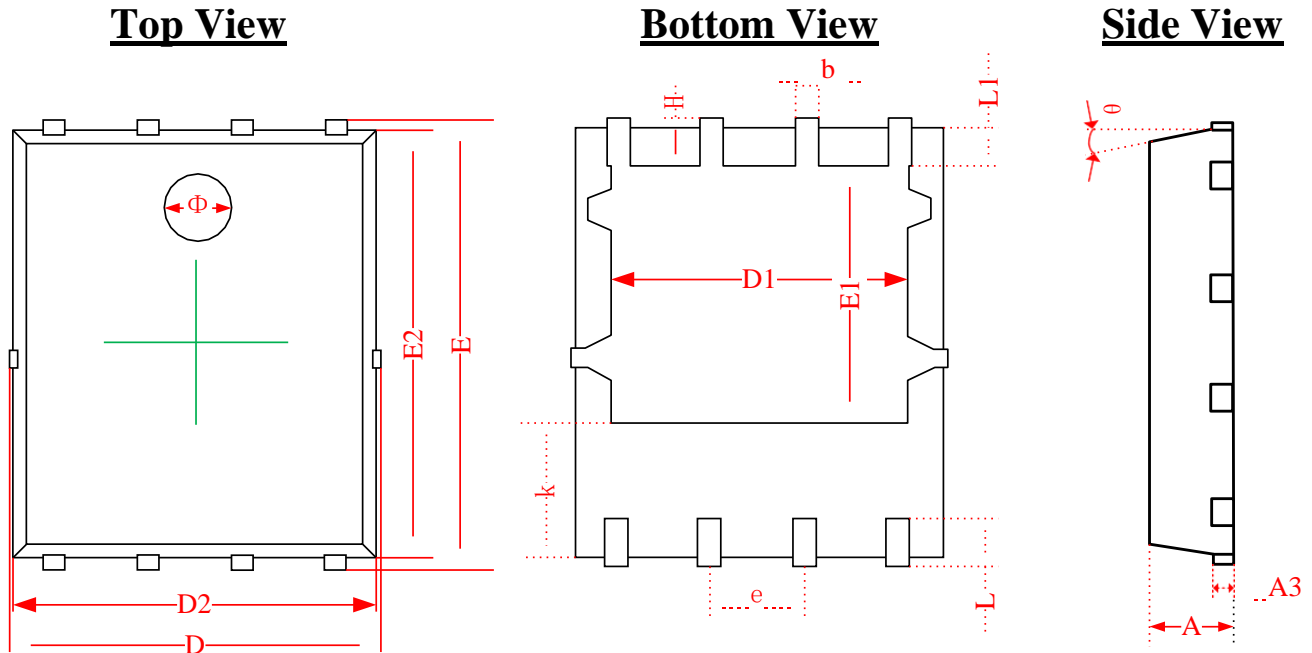

SYMBOLS	DIMENSIONS IN MILLIMETERS			DIMENSIONS IN INCHES		
	MIN	NOM	MAX	MIN	NOM	MAX
A	0.870	0.900	0.930	0.034	0.035	0.036
A3	0.152REF.			0.006REF.		
D	4.944	5.020	5.096	0.195	0.198	0.201
E	5.974	6.050	6.126	0.235	0.238	0.241
D1	3.910	4.010	4.110	0.154	0.158	0.162
E1	3.375	3.475	3.575	0.133	0.137	0.141
D2	4.870	4.900	4.930	0.192	0.193	0.194
E2	5.720	5.750	5.780	0.226	0.227	0.228
k	1.190	1.290	1.390	0.047	0.051	0.055
b	0.350	0.380	0.410	0.014	0.015	0.016
e	1.270TYP.			0.050TYP.		
L	0.559	0.635	0.711	0.022	0.025	0.028
L1	0.424	0.500	0.576	0.017	0.020	0.023
H	0.574	0.650	0.726	0.023	0.026	0.029
θ	10°	11°	12°	10°	11°	12°
Φ	1.150	1.200	1.250	0.045	0.047	0.049