

30V N And P-Channel Enhancement Mode MOSFET

Description

The PECN6601MR uses advanced trench technology to provide excellent $R_{DS(ON)}$ and low gate charge. The complementary MOSFETs may be used to form a level shifted high side switch, and for a host of other applications.

General Features

- ◆ **N-channel:**
 $V_{DS} = 30V, I_D = 4A$
 $R_{DS(ON)} = 33m\Omega$ (typical) @ $V_{GS} = 4.5V$
 $R_{DS(ON)} = 46m\Omega$ (typical) @ $V_{GS} = 2.5V$
- ◆ **P-Channel:**
 $V_{DS} = -30V, I_D = -2.3A$
 $R_{DS(ON)} = 85m\Omega$ (typical) @ $V_{GS} = -4.5V$
 $R_{DS(ON)} = 105m\Omega$ (typical) @ $V_{GS} = -2.5V$
- ◆ Excellent gate charge x $R_{DS(ON)}$ product(FOM)
- ◆ Very low on-resistance $R_{DS(ON)}$
- ◆ 150 °C operating temperature
- ◆ Pb-free lead plating
- ◆ 100% UIS tested

Application

- ◆ DC/DC Converter
- ◆ Ideal for high-frequency switching and synchronous rectification

Schematic diagram

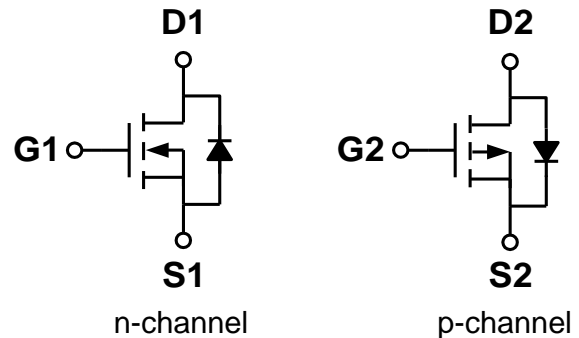

Marking and pin assignment

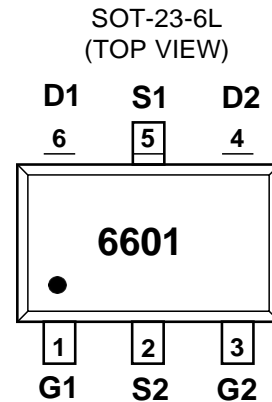

Package

- ◆ SOT-23-6L



Ordering Information

Part Number	Storage Temperature	Package	Devices Per Reel
PECN6601MR-G	-55°C to +150°C	SOT-23-6L	3000

Absolute Maximum Ratings (TA=25°C unless otherwise noted)

Parameter	Symbol	Limit		Unit
		N	P	
Drain-source voltage	V_{DS}	30	-30	V
Gate-source voltage	V_{GS}	±12	±12	V
Maximum power dissipation	P_D	1.1		W
Operating junction Temperature range	T_j	-55—150	-55—150	°C

Drain Current-Continuous (Silicon Limited)	$T_A=25^{\circ}\text{C}$	I_D	4	-2.3	A
	$T_A=75^{\circ}\text{C}$		3	-1.8	
Pulsed Drain Current (Package Limited) ^C		I_{DM}	16	-9	A
Junction and Storage Temperature Range		T_J, T_{STG}	-55—150		$^{\circ}\text{C}$

Thermal Characteristics

Parameter		Symbol	Typ	Max	Unit
Maximum Junction-to-Ambient ^A	$\leq 10\text{s}$	$R_{\theta JA}$	70	90	$^{\circ}\text{C}/\text{W}$
Maximum Junction-to-Ambient ^{A D}	Steady-State		100	125	
Maximum Junction-to-Lead ^B	Steady-State	$R_{\theta JL}$	63	80	

A. The value of $R_{\theta JA}$ is measured with the device mounted on 1in2 FR-4 board with 2oz. Copper, in a still air environment with $T_A=25^{\circ}\text{C}$. The value in any given application depends on the user's specific board design.

B. The power dissipation P_D is based on $T_{J(\text{MAX})}=150^{\circ}\text{C}$, using $\leq 10\text{s}$ junction-to-ambient thermal resistance.

C. Repetitive rating, pulse width limited by junction temperature $T_{J(\text{MAX})}=150^{\circ}\text{C}$. Ratings are based on low frequency and duty cycles to keep initial $T_J=25^{\circ}\text{C}$.

D. The $R_{\theta JA}$ is the sum of the thermal impedance from junction to lead $R_{\theta JL}$ and lead to ambient.

N-Channel Electrical Characteristics ($T_J=25^{\circ}\text{C}$ unless otherwise noted)

Parameter	Symbol	Condition	Min	Typ	Max	Unit
OFF Characteristics						
Drain-source breakdown voltage	BV_{DSS}	$V_{GS}=0\text{V}, I_D=250\mu\text{A}$	30	-	-	V
Zero gate voltage drain current	I_{DSS}	$V_{DS}=30\text{V}, V_{GS}=0\text{V}$	-	-	1	μA
Gate-body leakage	I_{GSS}	$V_{DS}=0\text{V}, V_{GS}=\pm 12\text{V}$	-	-	± 100	nA
ON Characteristics						
Gate threshold voltage	$V_{GS(th)}$	$V_{DS}=V_{GS}, I_D=250\mu\text{A}$	0.6	0.9	1.3	V
Drain-source on-state resistance	$R_{DS(ON)}$	$V_{GS}=4.5\text{V}, I_D=4\text{A}$	-	33	45	m Ω
		$V_{GS}=2.5\text{V}, I_D=3\text{A}$	-	46	60	
Forward transconductance	g_{fs}	$V_{DS}=5\text{V}, I_D=4\text{A}$	-	5	-	S
Dynamic Characteristics						
Input capacitance	C_{ISS}	$V_{DS}=15\text{V}, V_{GS}=0\text{V}$ $f=1.0\text{MHz}$	-	822	-	pF
Output capacitance	C_{OSS}		-	98	-	
Reverse transfer capacitance	C_{RSS}		-	76	-	
Switching Characteristics						
Turn-on delay time	$t_{D(ON)}$	$V_{DD}=15\text{V}$ $R_L=3.3\text{ohm}$ $V_{GEN}=4.5\text{V}$ $R_{GEN}=60\text{ohm}$	-	3.3	-	ns
Rise time	t_r		-	4.8	-	
Turn-off delay time	$t_{D(OFF)}$		-	25	-	
Fall time	t_f		-	4	-	
Total gate charge	Q_g	$V_{DS}=15\text{V}$ $I_D=4\text{A}$	-	9.5	-	nC
Gate-source charge	Q_{gs}		-	1.5	-	

Gate-drain charge	Qgd	V _{GS} =4.5V	-	3	-	
DRAIN-SOURCE DIODE CHARACTERISTICS						
Diode forward voltage	V _{SD}	V _{GS} =0V, I _S =3A	-	0.76	1.16	V

P-Channel Electrical Characteristics (T_J=25°C unless otherwise noted)

Parameter	Symbol	Condition	Min	Typ	Max	Unit
OFF Characteristics						
Drain-source breakdown voltage	BV _{DSS}	V _{GS} =0V, I _D =-250μA	-30	-	-	V
Zero gate voltage drain current	I _{DSS}	V _{DS} =-30V, V _{GS} =0V	-	-	-1	μA
Gate-body leakage	I _{GSS}	V _{DS} =0V, V _{GS} =±12V	-	-	±100	nA
ON Characteristics						
Gate threshold voltage	V _{GS(th)}	V _{DS} =V _{GS} , I _D =-250μA	-0.4	-0.65	-1.2	V
Drain-source on-state resistance	R _{DS(ON)}	V _{GS} =-4.5V, I _D =-2.3A	-	85	120	mΩ
		V _{GS} =-2.5V, I _D =-1.5A	-	105	140	
Forward transconductance	g _{fs}	V _{DS} =-5V, I _D =-2A	-	3	-	S
Dynamic Characteristics						
Input capacitance	C _{ISS}	V _{DS} =-15V, V _{GS} =0V f=1.0MHz	-	561	-	pF
Output capacitance	C _{OSS}		-	61	-	
Reverse transfer capacitance	C _{RSS}		-	52	-	
Switching Characteristics						
Turn-on delay time	t _{D(ON)}	V _{DD} =-15V I _D =-2.3A V _{GEN} =-4.5V R _L =10ohm R _{GEN} =60ohm	-	12.5	-	ns
Rise time	t _r		-	6.6	-	
Turn-off delay time	t _{D(OFF)}		-	113	-	
Fall time	t _f		-	46.6	-	
Total gate charge	Q _g	V _{DS} =-15V, I _D =-2.3A V _{GS} =-4.5V	-	6.1	-	nC
Gate-source charge	Q _{gs}		-	1.7	-	
Gate-drain charge	Q _{gd}		-	1.2	-	
DRAIN-SOURCE DIODE CHARACTERISTICS						
Diode forward voltage	V _{SD}	V _{GS} =0V, I _S =-1.25A	-	-0.81	-1.2	V

Package Information

- SOT-23-6L

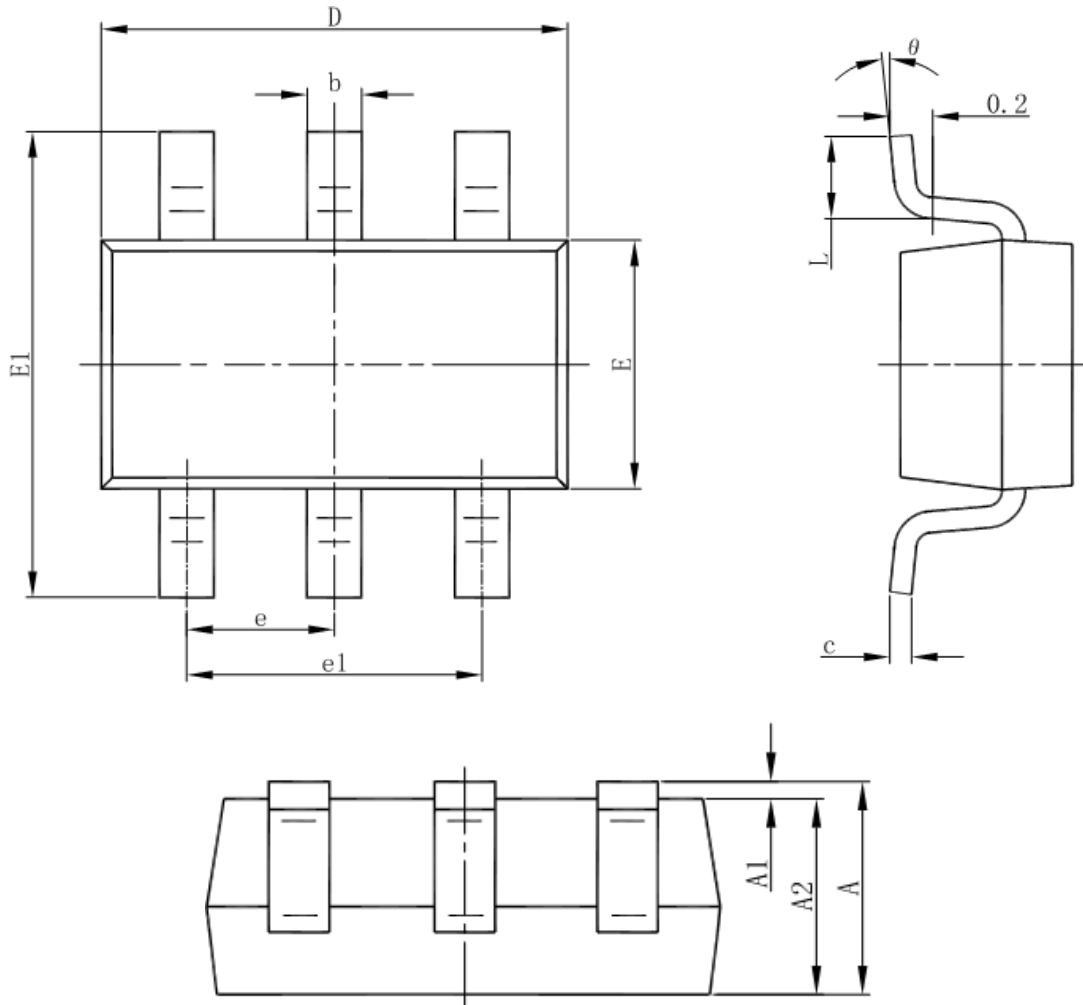

Symbol	Dimensions In Millimeters		Dimensions In Inches	
	Min	Max	Min	Max
A	1.050	1.250	0.041	0.049
A1	0.000	0.100	0.000	0.004
A2	1.050	1.150	0.041	0.045
b	0.300	0.500	0.012	0.020
c	0.100	0.200	0.004	0.008
D	2.820	3.020	0.111	0.119
E	1.500	1.700	0.059	0.067
E1	2.650	2.950	0.104	0.116
e	0.950(BSC)		0.037(BSC)	
e1	1.800	2.000	0.071	0.079
L	0.300	0.600	0.012	0.024
θ	0°	8°	0°	8°