

## 20V Dual N-Channel Enhancement Mode MOSFET

### Description

The NP9926BSR uses advanced trench technology and design to provide excellent  $R_{DS(ON)}$  with low gate charge. It can be used in a wide variety of applications.

### General Features

- ◆  $V_{DS} = 20V$ ,  $I_D = 6A$   
 $R_{DS(ON)}(Typ.) = 28m\Omega$  @  $V_{GS} = 2.5V$   
 $R_{DS(ON)}(Typ.) = 24m\Omega$  @  $V_{GS} = 4.5V$
- ◆ High density cell design for ultra low  $R_{dson}$
- ◆ Fully characterized avalanche voltage and current

### Application

- ◆ SOP-8

*100% UIS TESTED!*  
*100%  $\Delta V_{ds}$  TESTED!*



### Schematic diagram

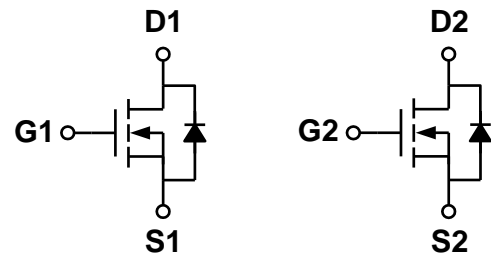

### Marking and pin assignment

SOP-8  
(TOP VIEW)

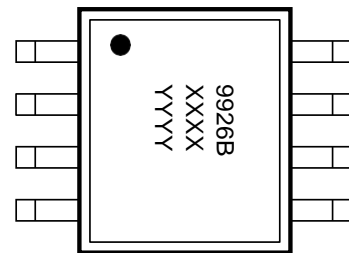

Note: XXXX is the date code, YYYY is the Quality code

### Ordering Information

Part Number	Storage Temperature	Package	Devices Per Reel
PECN9926BSR-G	-55°C to +150°C	SOP-8	4000

### Absolute Maximum Ratings (TA=25°C unless otherwise noted)

parameter	symbol	limit	unit	
Drain-source voltage	$V_{DS}$	20	V	
Gate-source voltage	$V_{GS}$	$\pm 12$	V	
Drain Current-Continuous (Silicon Limited)	$I_D$	$T_A = 25^\circ C$	6	A
		$T_A = 75^\circ C$	4	
Pulsed Drain Current (Package Limited)	$I_{DM}$	24	A	
Maximum power dissipation	$P_D$	$T_A = 25^\circ C$	1.25	W
		$T_A = 75^\circ C$	0.8	
Operating junction Temperature range	$T_j$	-55—150	°C	

## Electrical Characteristics (TA=25°C unless otherwise noted)

Parameter	Symbol	Condition	Min	Typ	Max	Unit
<b>OFF Characteristics</b>						
Drain-source breakdown voltage	$BV_{DSS}$	$V_{GS}=0V, I_D=250\mu A$	20	-	-	V
Zero gate voltage drain current	$I_{DSS}$	$V_{DS}=20V, V_{GS}=0V$	-	-	1	$\mu A$
Gate-body leakage	$I_{GSS}$	$V_{DS}=0V, V_{GS}=\pm 12V$	-	-	$\pm 100$	nA
<b>ON Characteristics</b>						
Gate threshold voltage	$V_{GS(th)}$	$V_{DS}=V_{GS}, I_D=250\mu A$	-0.5	0.7	1.2	V
Drain-source on-state resistance	$R_{DS(ON)}$	$V_{GS}=4.5V, I_D=6A$	-	24	28	m $\Omega$
		$V_{GS}=2.5V, I_D=5A$	-	28	35	
Forward transconductance	$g_{fs}$	$V_{GS}=5V, I_D=6A$	-	10	-	S
<b>Dynamic Characteristics</b>						
Input capacitance	$C_{ISS}$	$V_{DS}=10V, V_{GS}=0V$ $f=1.0MHz$	-	900	-	pF
Output capacitance	$C_{OSS}$		-	220	-	
Reverse transfer capacitance	$C_{RSS}$		-	100	-	
<b>Switching Characteristics</b>						
Turn-on delay time	$t_{D(ON)}$	$V_{DD}=10V$ $I_D=6A$ $V_{GEN}=4.5V$ $R_{GEN}=6ohm$	-	10	-	ns
Rise time	$t_r$		-	11	-	
Turn-off delay time	$t_{D(OFF)}$		-	35	-	
Fall time	$t_f$		-	30	-	
Total gate charge	$Q_g$	$V_{DS}=10V, I_D=6A$ $V_{GS}=4.5V$	-	12	-	nC
Gate-source charge	$Q_{gs}$		-	2.3	-	
Gate-drain charge	$Q_{gd}$		-	1	-	

## Thermal Characteristics

Thermal Resistance junction-to ambient	$R_{\theta JA}$	100	$^{\circ}C/W$
----------------------------------------	-----------------	-----	---------------

## Typical Performance Characteristics

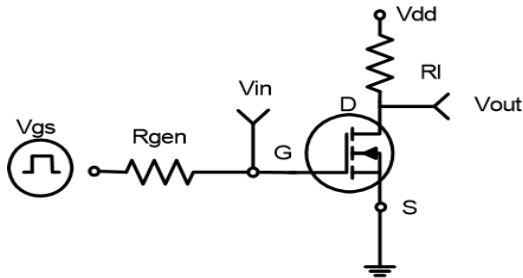

Figure 1: Switching Test Circuit

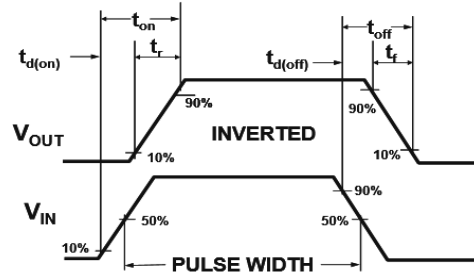

Figure 2: Switching Waveforms

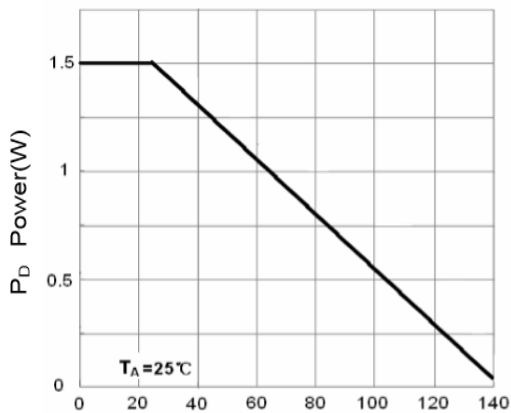

Figure 3 Power Dissipation

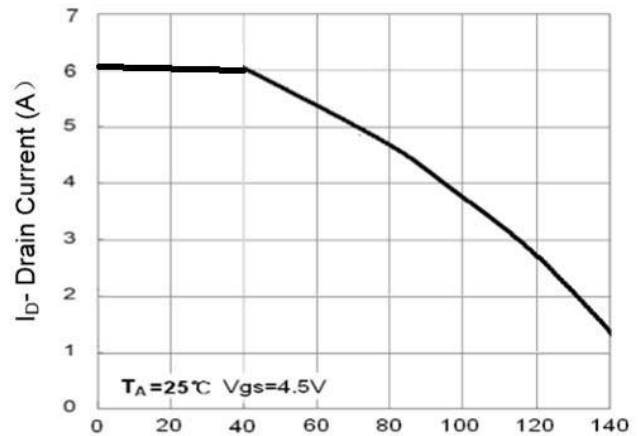

Figure 4 Drain Current

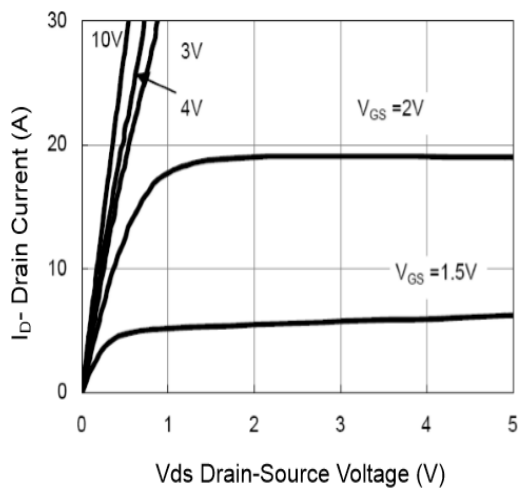

Figure 5 Output Characteristics

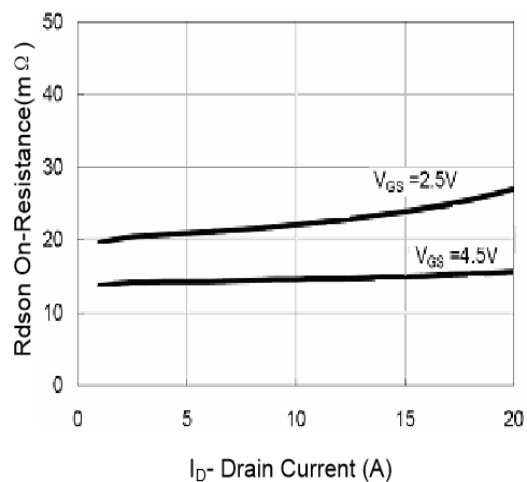
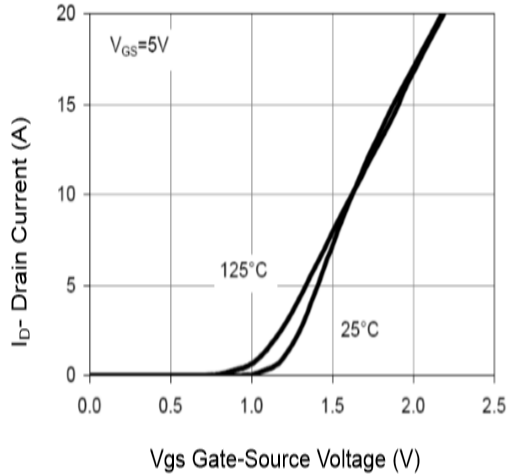
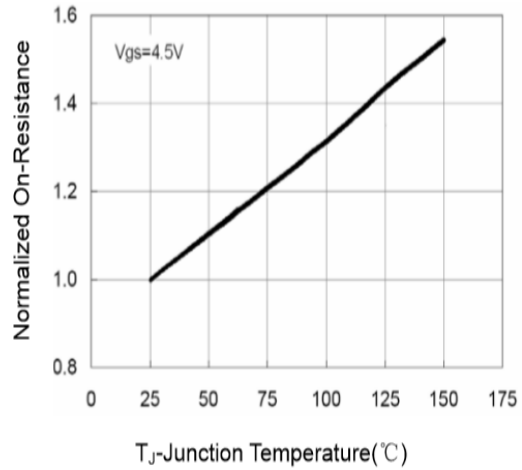

Figure 6 Drain-Source On-Resistance



**Figure 7 Transfer Characteristics**



**Figure 8 Drain-Source On-Resistance**

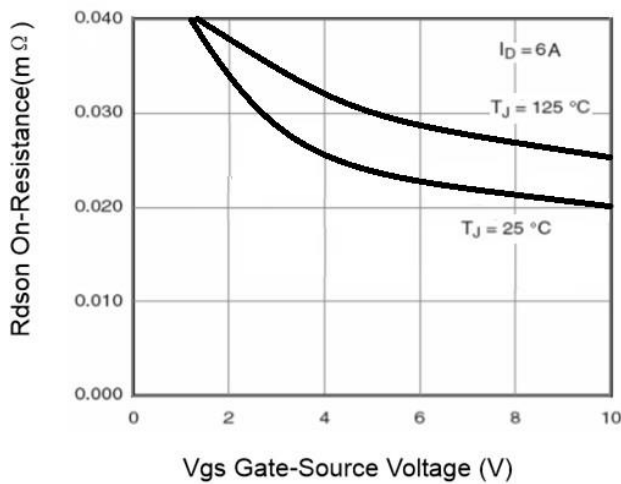

**Figure 9 Rdson vs Vgs**

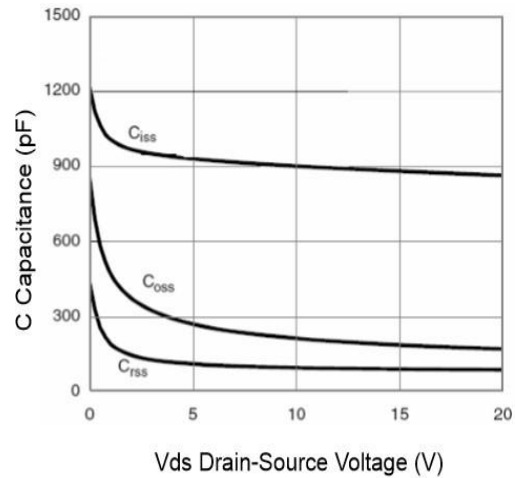

**Figure 10 Capacitance vs Vds**

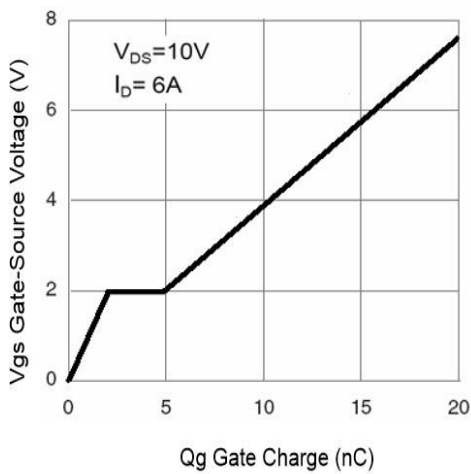

**Figure 11 Gate Charge**

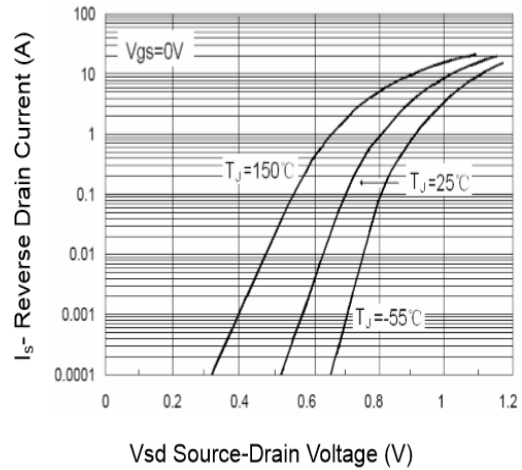

**Figure 12 Source- Drain Diode Forward**

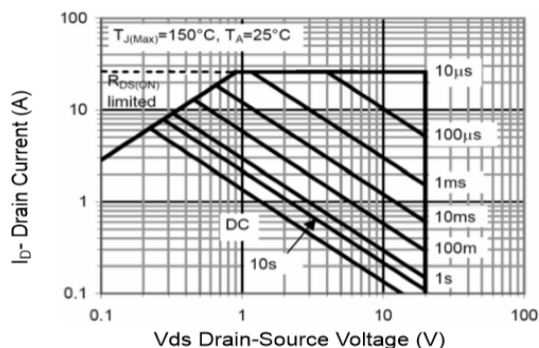

**Figure 13 Safe Operation Area**

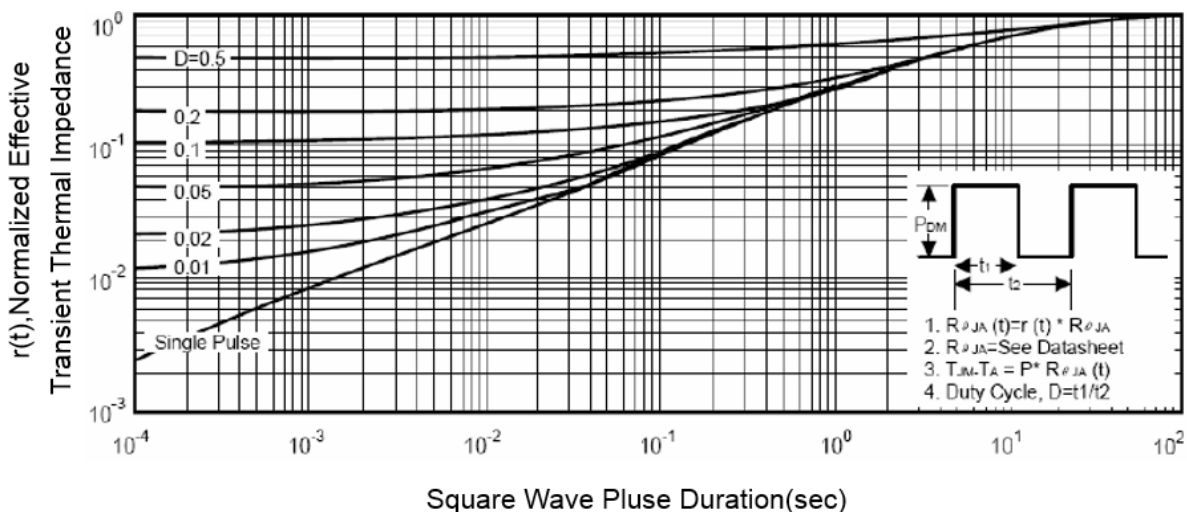

**Figure 14 Normalized Maximum Transient Thermal Impedance**

## Test Circuit:

1 、 EAS Test Circuit

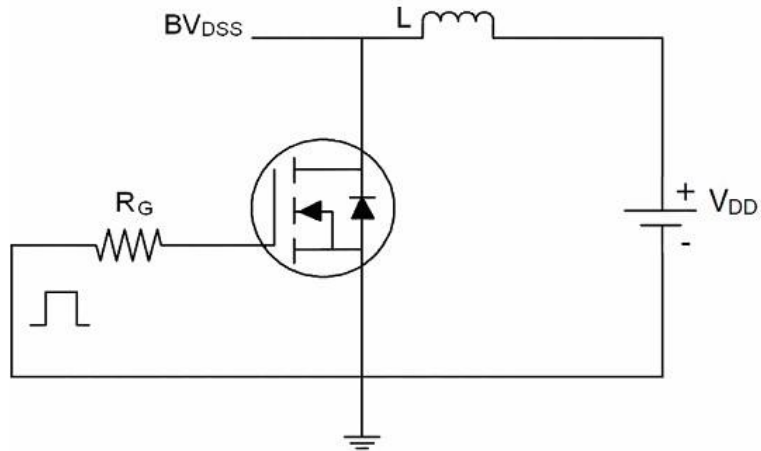

2 、 Gate Charge Test Circuit

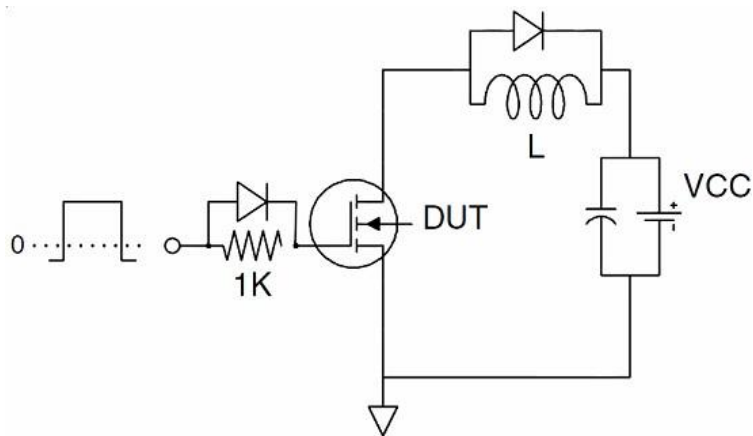

3 、 Switch Time Test Circuit

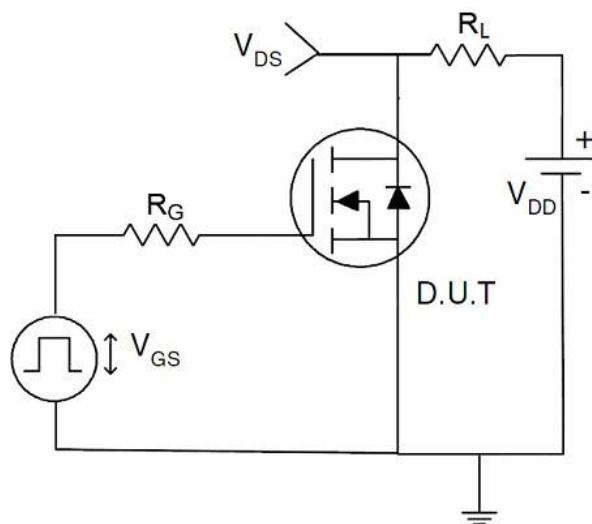

## Package Information

## ● SOP-8

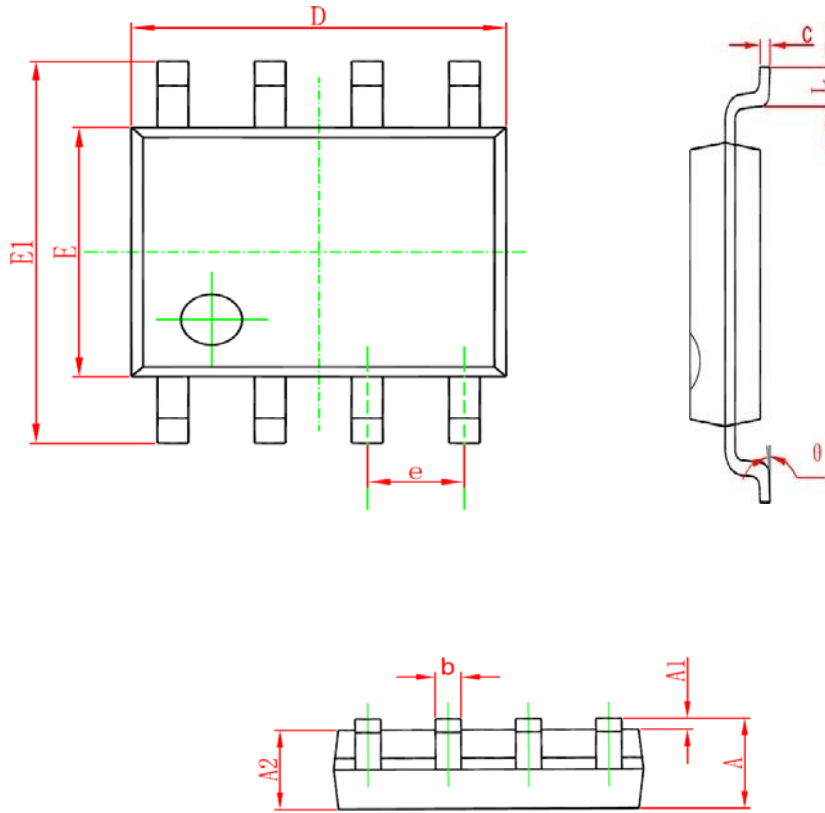

Symbol	Dimensions In Millimeters		Dimensions In Inches	
	Min	Max	Min	Max
A	1.350	1.750	0.053	0.069
A1	0.100	0.250	0.004	0.010
A2	1.350	1.550	0.053	0.061
b	0.330	0.510	0.013	0.020
c	0.170	0.250	0.006	0.010
D	4.700	5.100	0.185	0.200
E	3.800	4.000	0.150	0.157
E1	5.800	6.200	0.228	0.244
e	1.270 (BSC)		0.050 (BSC)	
L	0.400	1.270	0.016	0.050
θ	0°	8°	0°	8°

**Recommended Minimum Pads**

● SOP-8

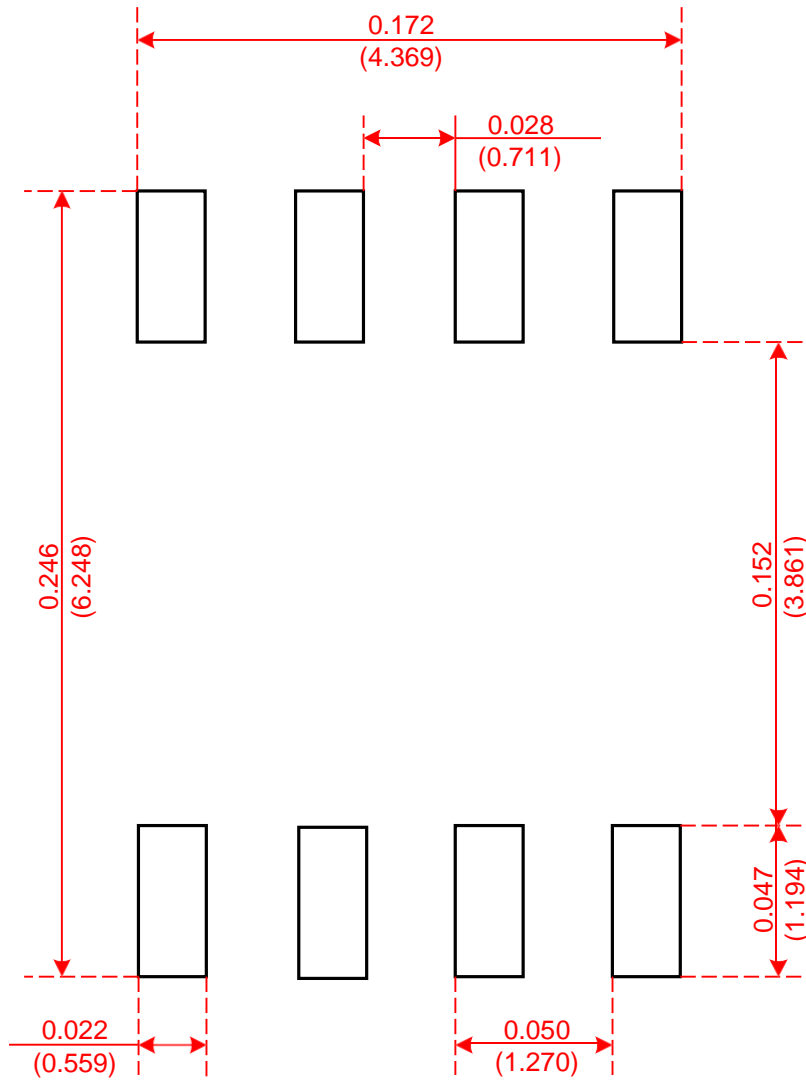

Recommended Minimum Pads  
Dimensions in Inches/(mm)

Tape and Reel

● SOP-8



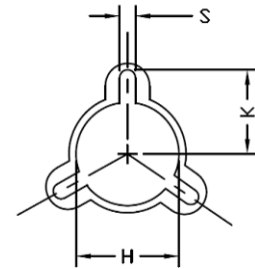
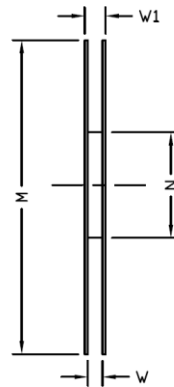
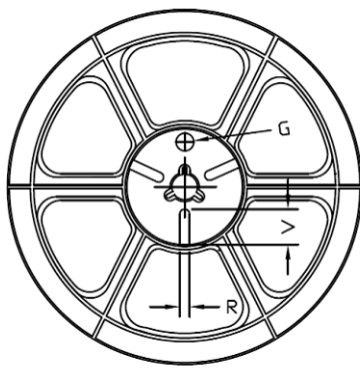
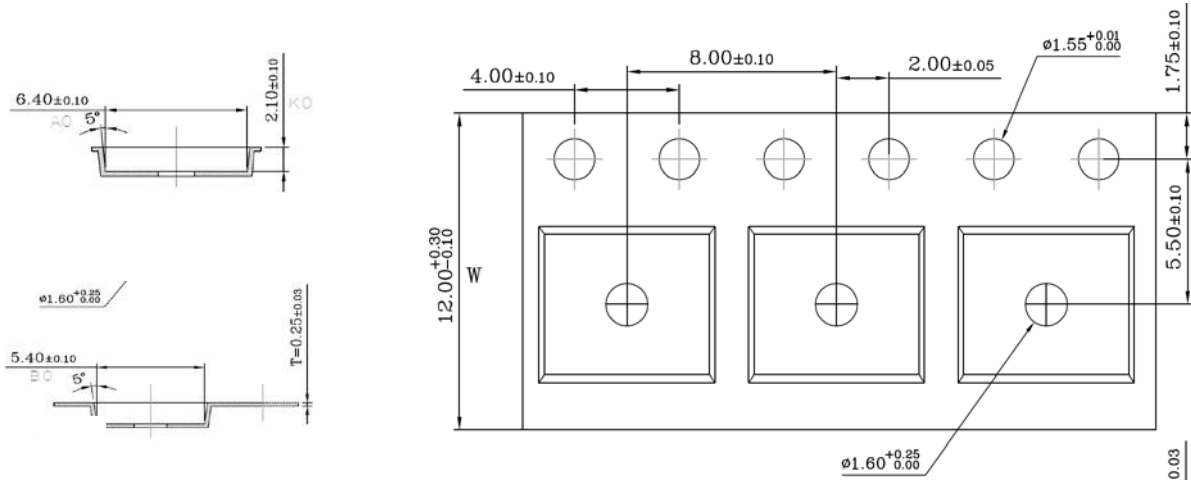

Tape Size	Reel Size	M	N	W	W1	H	K	S	G	R	V
12mm	Φ330	Φ330.00 ±0.50	Φ97.00 ±0.30	13.00 ±0.30	17.40 ±1.00	Φ13.00 ±0.5	10.6	2.00 ±0.50	—	—	—

Unit Per Reel:  
4000pcs

